

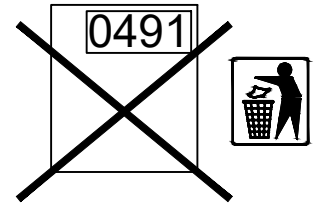

0492  
00

  IF YOU ARE INSTALLING THE DOUBLE FRAME KIT, JUST FOLLOW THESE INSTRUCTION

  SI ESTA' INSTALANDO EL MARCO DOBLE, SIGA ESTAS INSTRUCCIONES



# ECLISSE SYNTESIS SLIDE DOUBLE 2X4

# ECLISSE SYNTESIS SLIDE DOUBLE 2X6

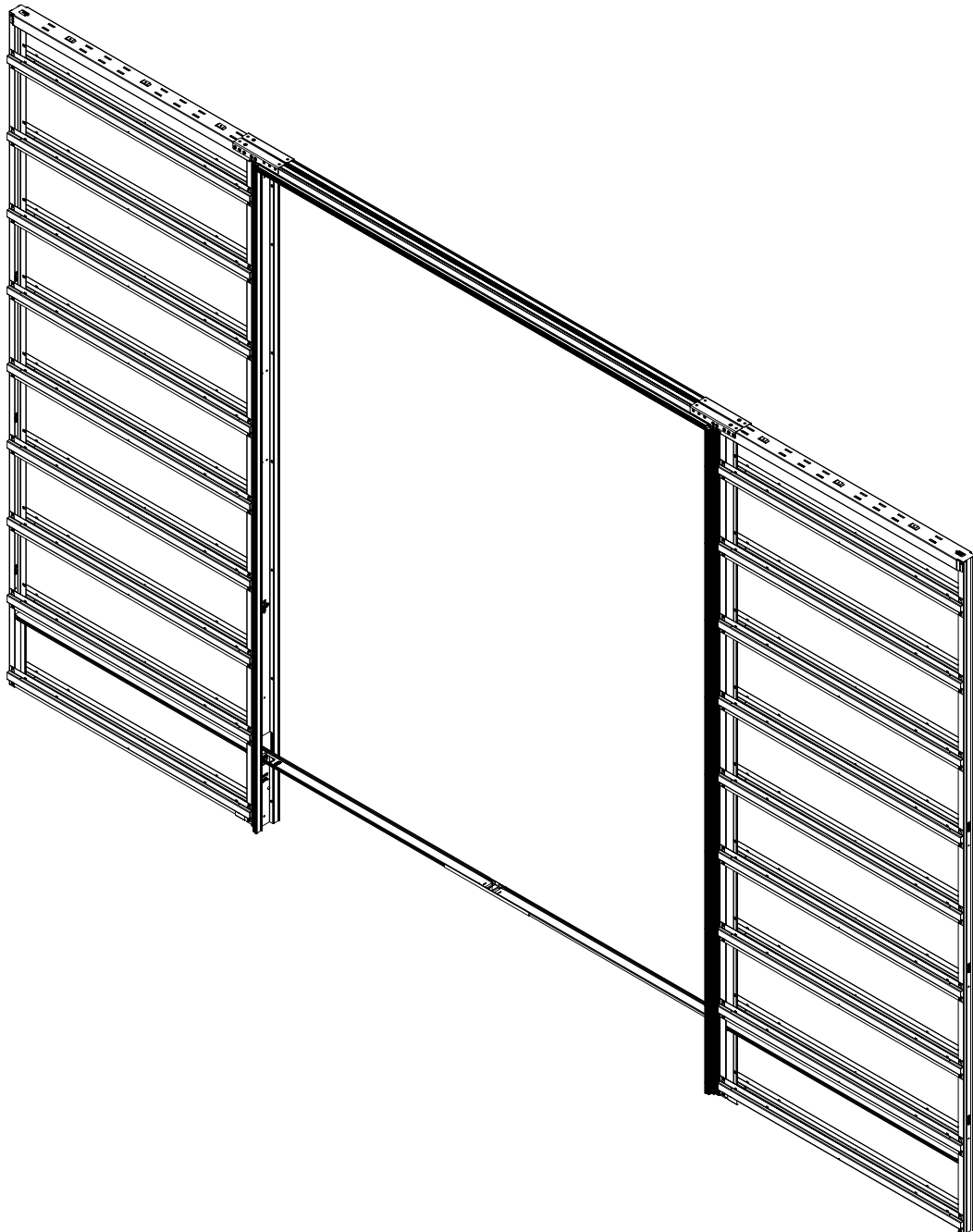



**EN** By following these Frame assembly and installation instructions carefully, it will make the process and experience much easier.  
A pair of horses are very useful when assembling the frame.  
Some parts may have sharp edges so use gloves and be careful when handling the parts.  
All ECLISSE products are fully inspected and tested before they leave the factory.



**ES** Seguir las instrucciones con atención.  
Para un montaje correcto, utilizar las herramientas indicadas, y para una correcta funcionalidad, ensamblar en los soportes adecuados.  
Algunas partes del producto pueden contener superficie punzantes y/o cortantes. Se necesita utilizar dispositivos de protección adecuados y proteger los espacios de trabajo.  
"ECLISSE SRL" no asume responsabilidad alguna por los daños derivados en la utilización no conforme a estas instrucciones.  
Todos los componentes del contramarco están testados y controlados en ECLISSE.

## MANDATORY TOOLS HERRAMIENTAS OBLIGATORIAS PARA EL MONTAJE

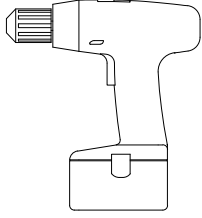

PH2  
DRILL  
DESTORNILLADOR

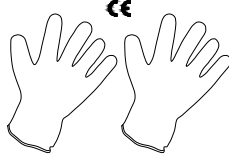

GLOVES  
GUANTES

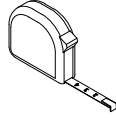

TAPE MEASURE  
METRO

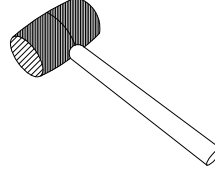

HAMMER  
MARTILLO

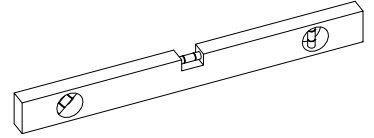

LEVEL  
NIVEL DE BURBUJA

## FRAME COMPONENTS / COMPONENTES DEL KIT

**a** 2 x

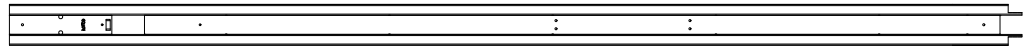

CENTRAL VERTICAL / MONTANTES VERTICALES DELANTERO

**b** 2 x



REAR VERTICAL / MONTANTE VERTICAL TRASERO

**c** 24/28/  
32/36 x

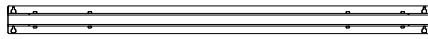

HORIZONTAL BARS (N°24 PCS FOR H = 80"-84" / N°28 PCS FOR H = 90"-96" / N°32 PCS FOR H = 108" / N°36 PCS FOR H = 120")  
REFUERZOS HORIZONTALES (N° 24 PARA H = 80"-84" / N° 28 PARA H = 90"-96" / N°32 PARA H = 108" / N°36 PARA H = 120")

**d** 2 x

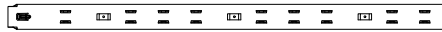

POCKET HEADER / SUBREPUERTA

**p** 1 x

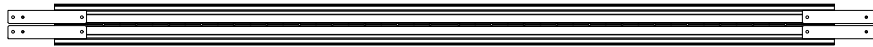

TOP BEAM / GUIA

**q** 2 x



TRACK / RIEL

**h** 1 x

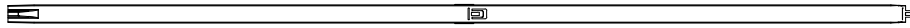

ALIGNMENT BAR / BARRA DE ALINEACIÓN

**r** 1 x



ALIGNMENT BAR / BARRA DE ALINEACIÓN

**h** 2 x

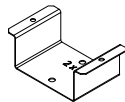

BRACKET / SOPORTE

**j** 65 x

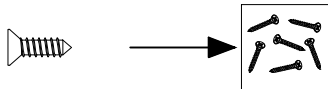

SCREWS / TORNILLOS  
ST FH #7 X 1/2" (3,9x13 mm)

**k** 2 x

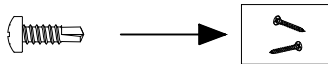

SCREWS / TORNILLOS  
ST FH #7 X 3/8" (3,9x9,5 mm)

**l** 144 x

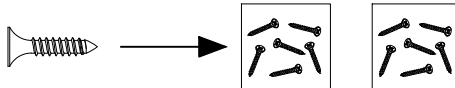

SCREWS / TORNILLOS  
ST FH #7 X 1" (3,9x25 mm)

1 x



RUNNER KIT /  
HERRAMIENTAS

2 x

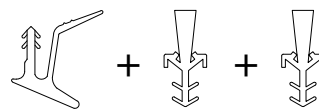

GASKETS AND BRUSHES /  
JUNTAS Y CEPILLOS

2 x

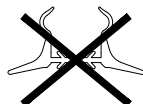

GASKETS/  
JUNTAS



2 x



FRONT VERTICAL / MONTANTE DE TOPE



1 x 2

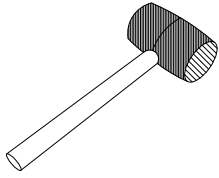

Assemble the Horizontal Bars (c) securely on Central Verticals (a) and Rear Verticals (b) at the predetermined positions. Make sure they are firmly locked in place.

Encajar los Refuerzos Horizontales (c) de forma segura en los Montantes Verticales Delantero (a) y el Montante Vertical Trasero (b) en las posiciones predeterminadas. Asegúrese de que estén firmemente bloqueados en su lugar.

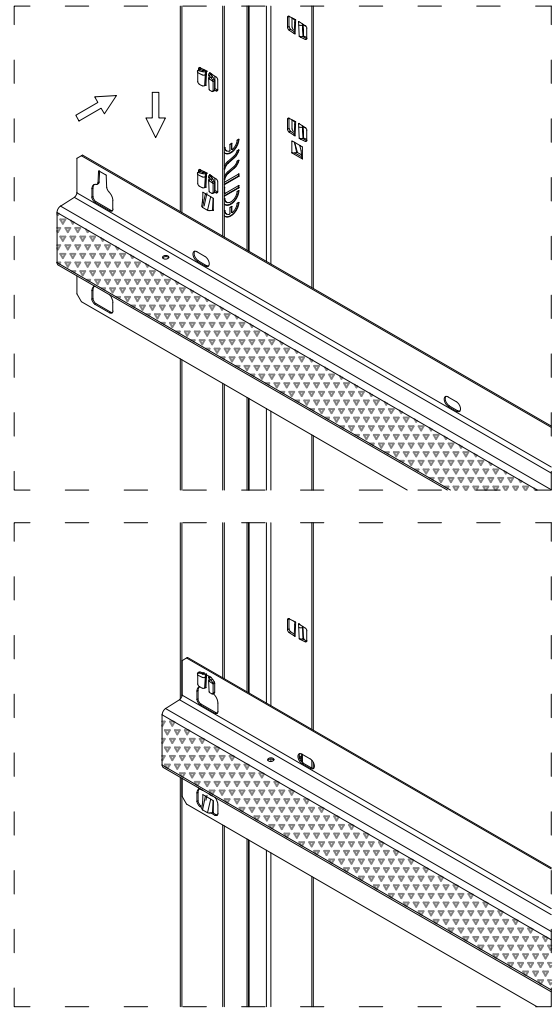
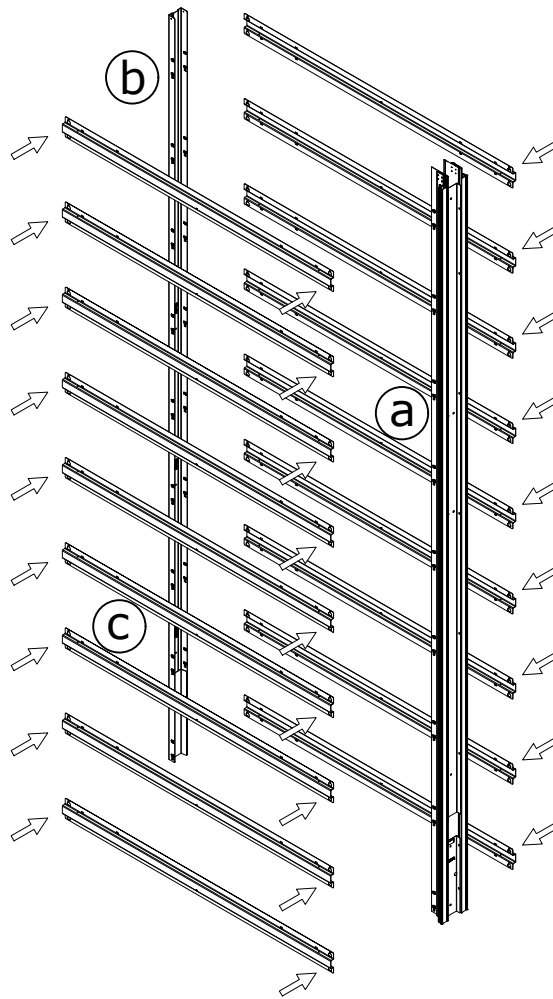

2 x 2

Assemble the Pocket Header (d) to the Central Vertical (a) and Rear Vertical (b) with screws (j).

Ensamblar el Sobrepuerta (d) en el Montantes Verticales Delantero (a) y el Montante Vertical Trasero (b) con tornillos (j).

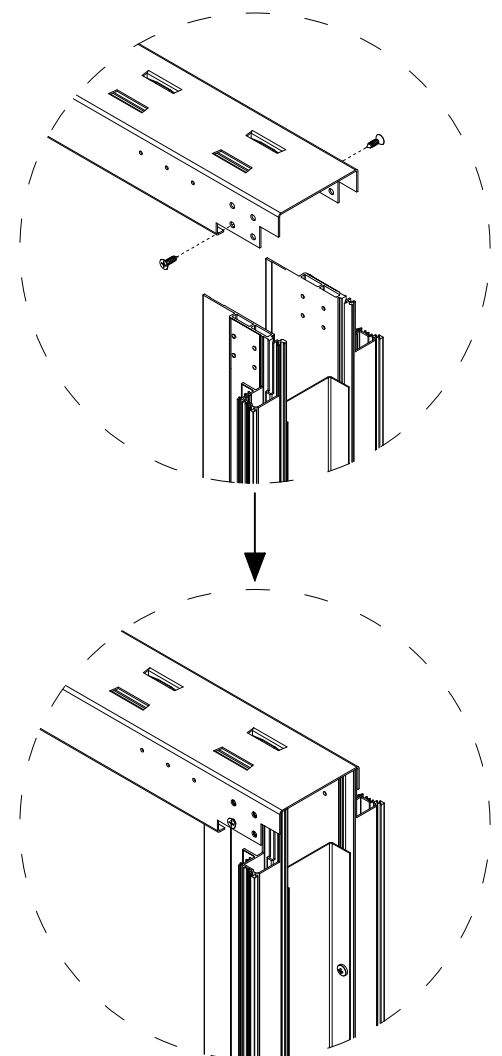
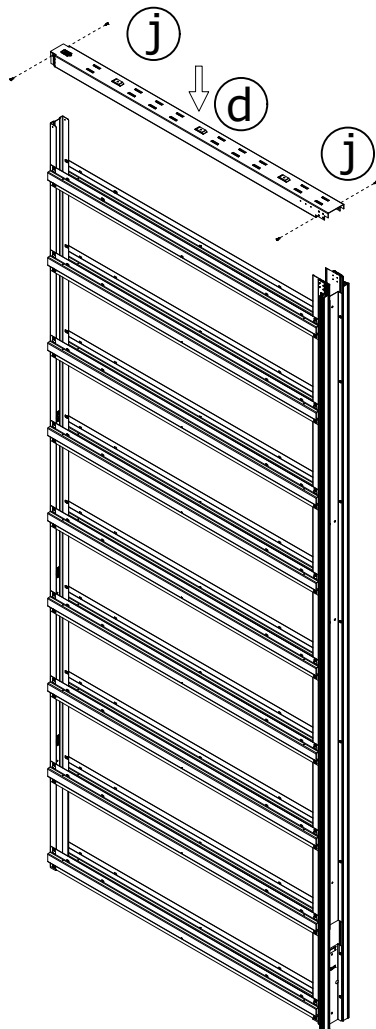

**3** x 2

Fix the Bracket (h) at the bottom of the Central Verticals (a) with screws (j).

*Fijar el Soporte (h) en la parte inferior de los Montantes Verticales Delantero (a) con los tornillos (j).*

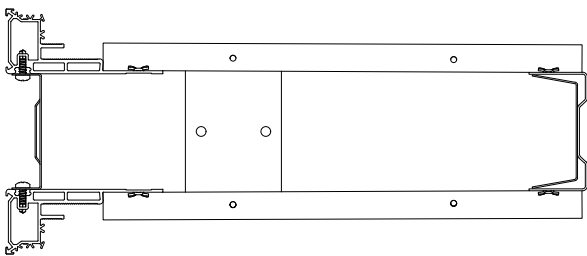
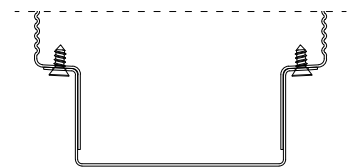
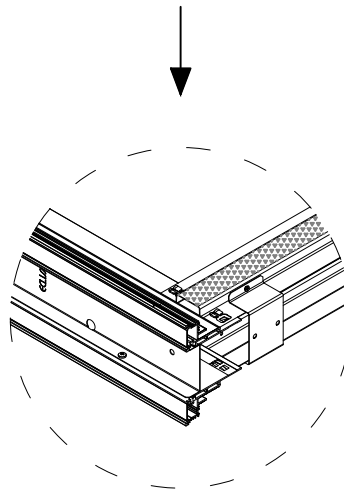
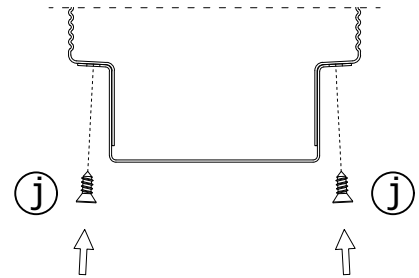
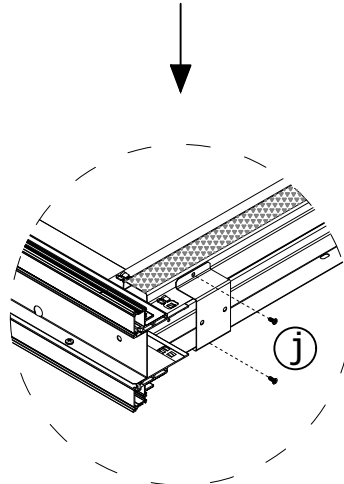
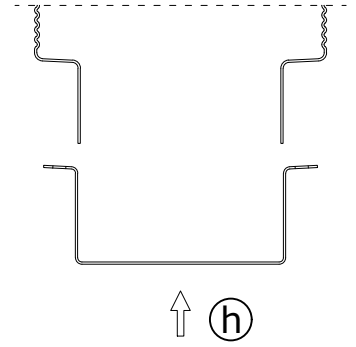
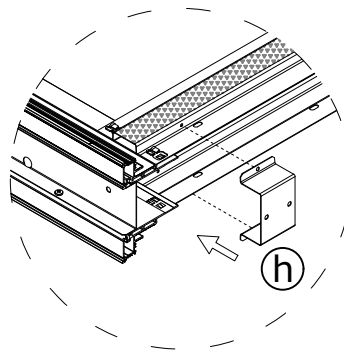
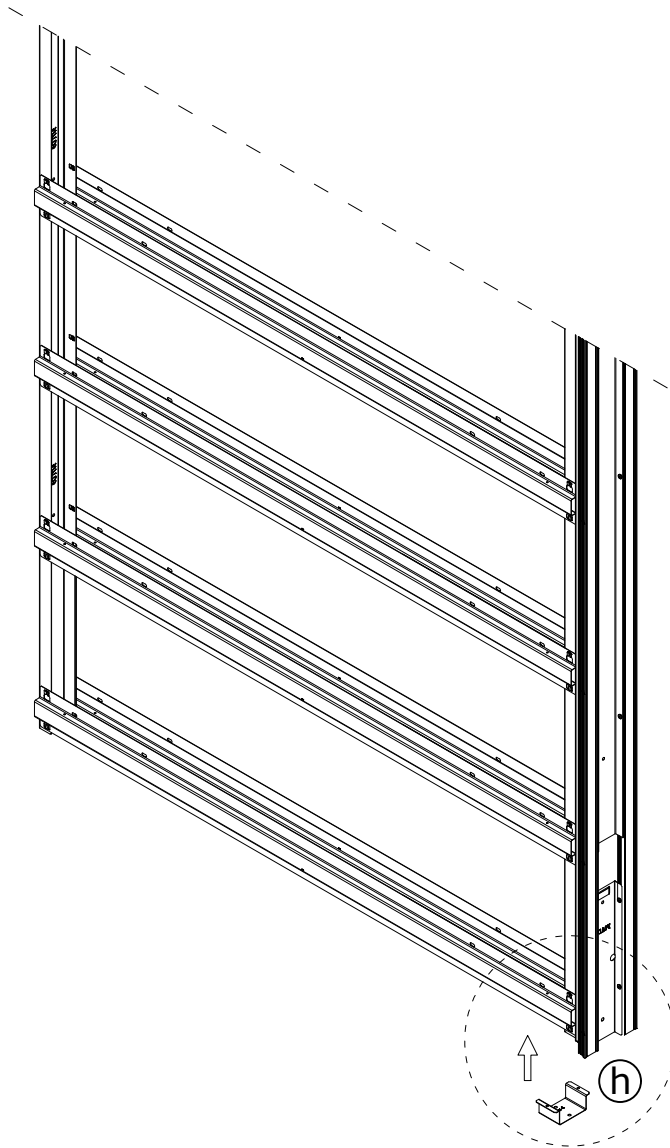

**(EN)** IF YOU ARE INSTALLING THE 2X6 "LUCE" FRAME, BEFORE CONTINUING, FOLLOW THE INSTRUCTIONS INSIDE THE "LUCE KIT" PACKAGE.



**(ES)** SI ESTÁ INSTALANDO EL MARCO DE 2X6 "LUCE", ANTES DE CONTINUAR, SIGA LAS INSTRUCCIONES DENTRO DEL PAQUETE DEL "LUCE KIT".

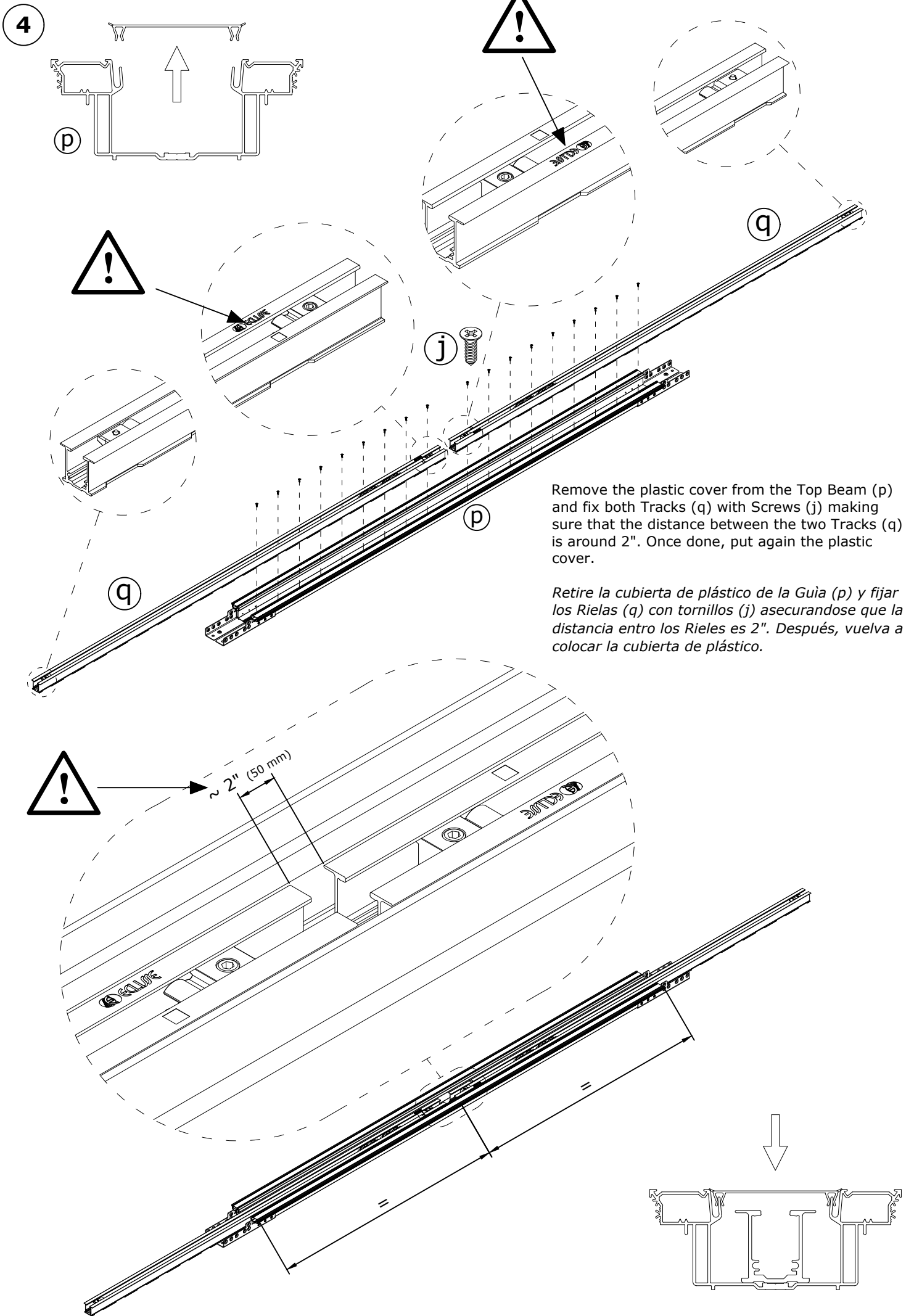

5

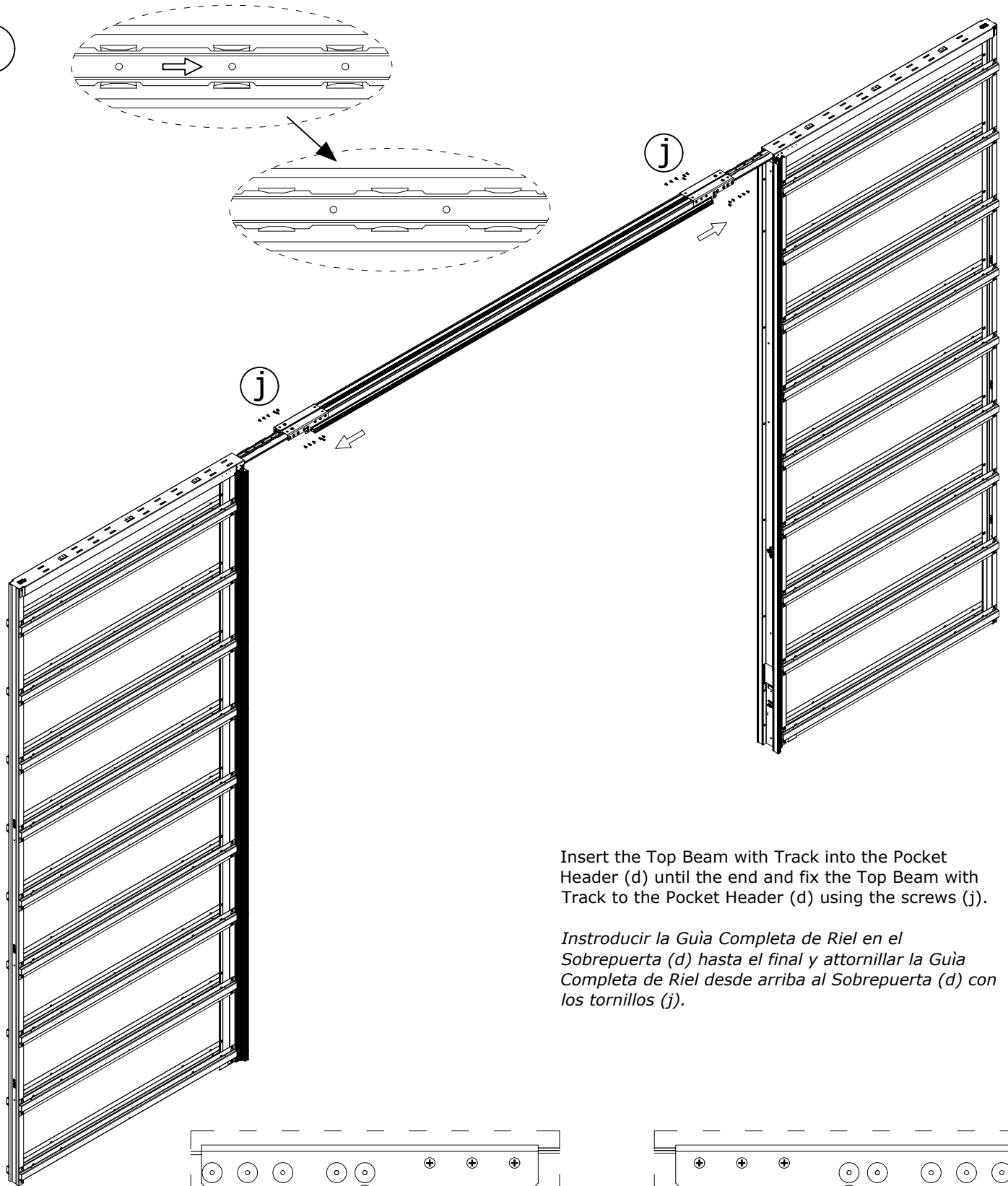

Insert the Top Beam with Track into the Pocket Header (d) until the end and fix the Top Beam with Track to the Pocket Header (d) using the screws (j).

*Introducir la Guía Completa de Riel en el Sobrepuerta (d) hasta el final y atornillar la Guía Completa de Riel desde arriba al Sobrepuerta (d) con los tornillos (j).*

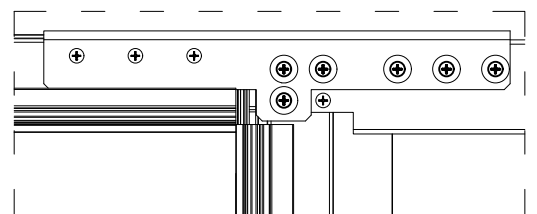
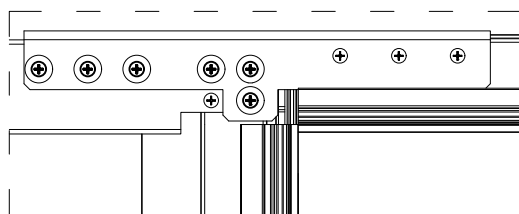
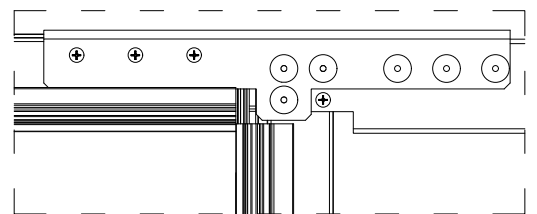
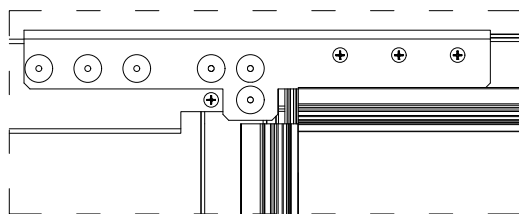

6

Bend the end of the Alignment Bar (h and r) backwards 90°.

*Doblar las extremidades de los Barra de Alineación (h y r) de 90°.*

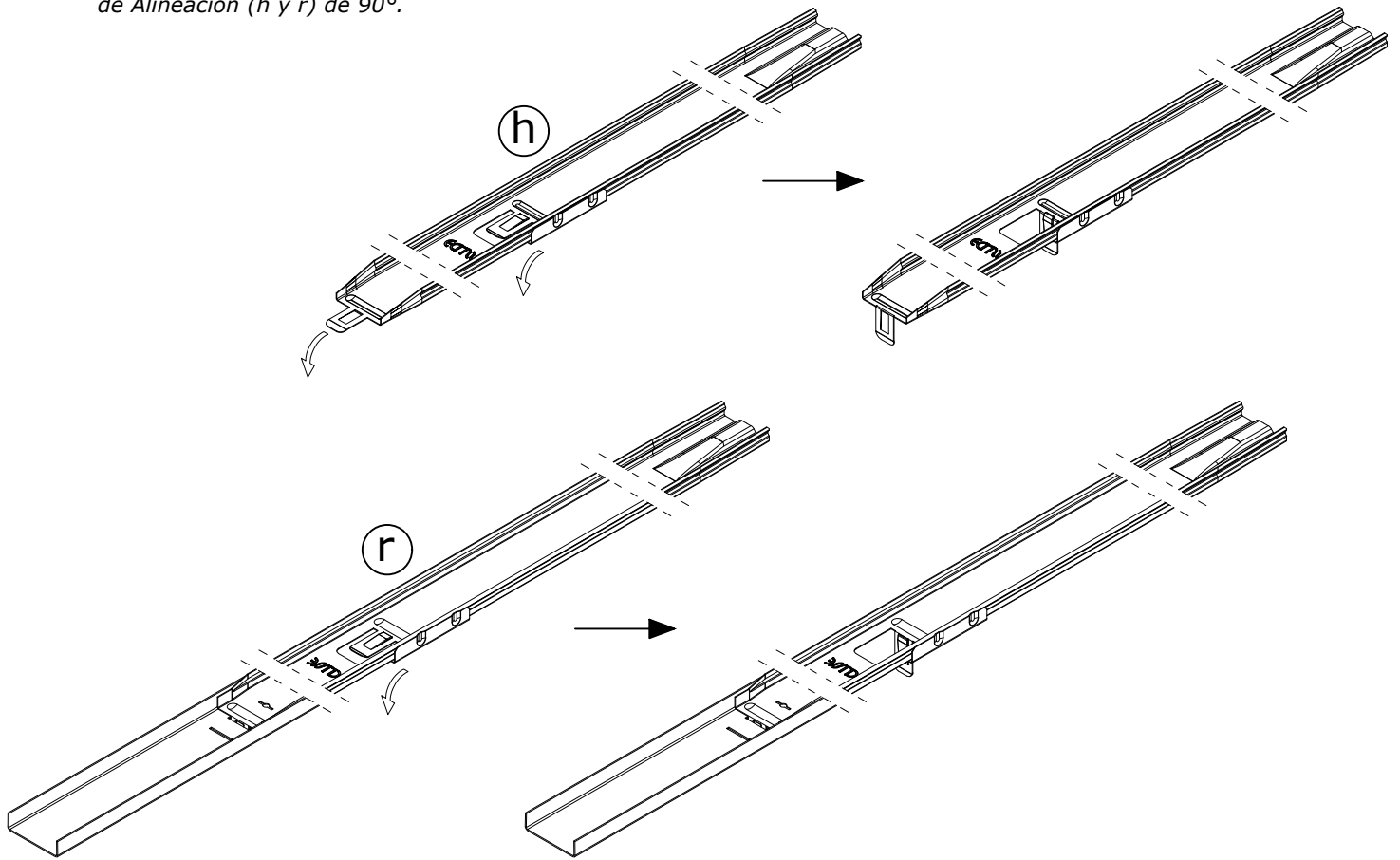

7

Insert the Alignment Bars (h and r) through the Central Vertical (a) until they touch the Rear Verticals (b) and secure them both together into position on Central Vertical (a).

*Insertar las Barras de Alineación (h y r) a los Montantes Verticales Delantero (a) hasta el Montante Vertical Trasero (b) y fijarlos juntos a los Montantes Verticales Delantero (a).*

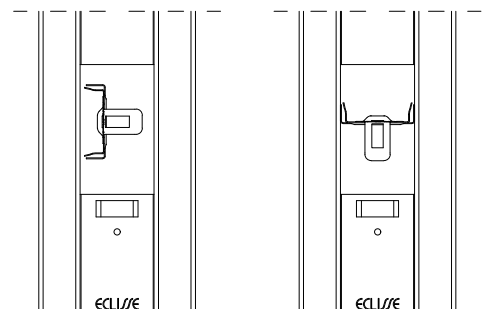
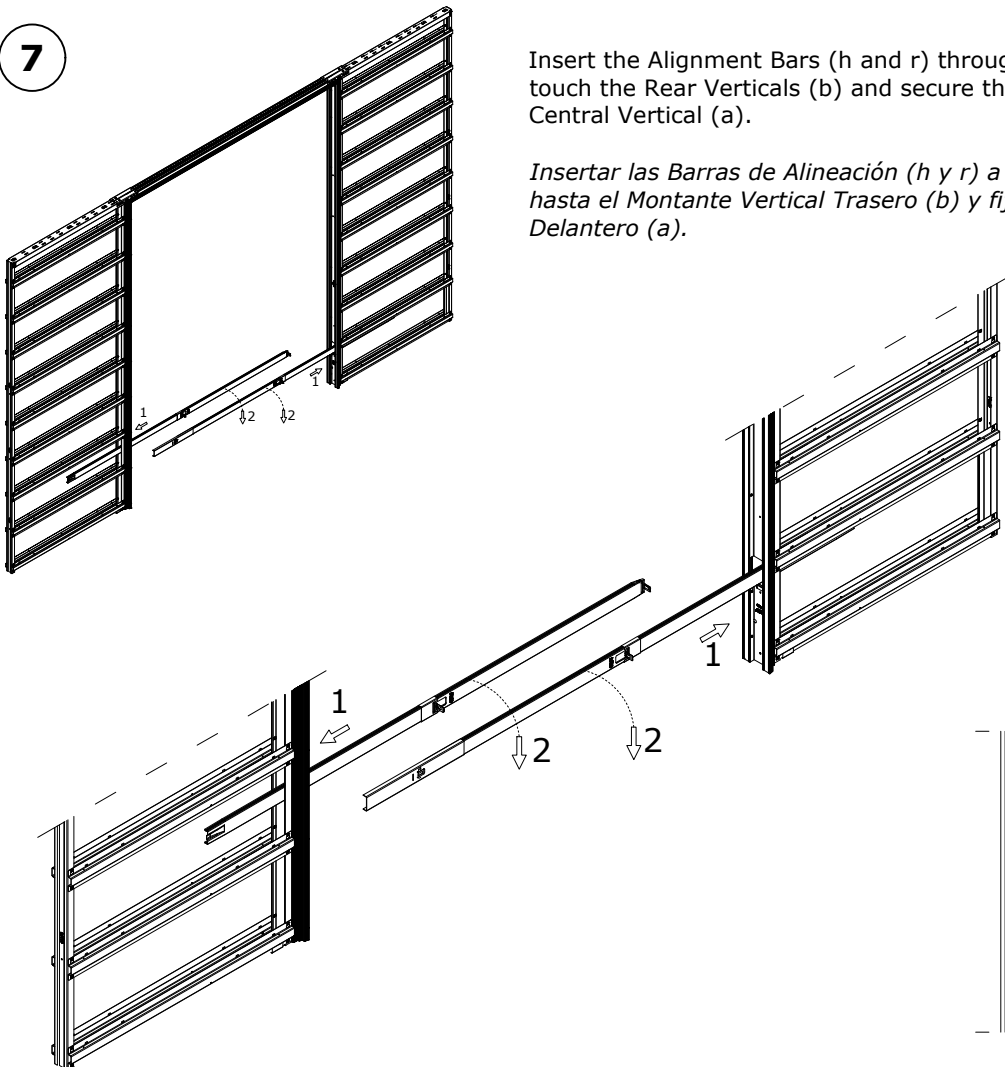

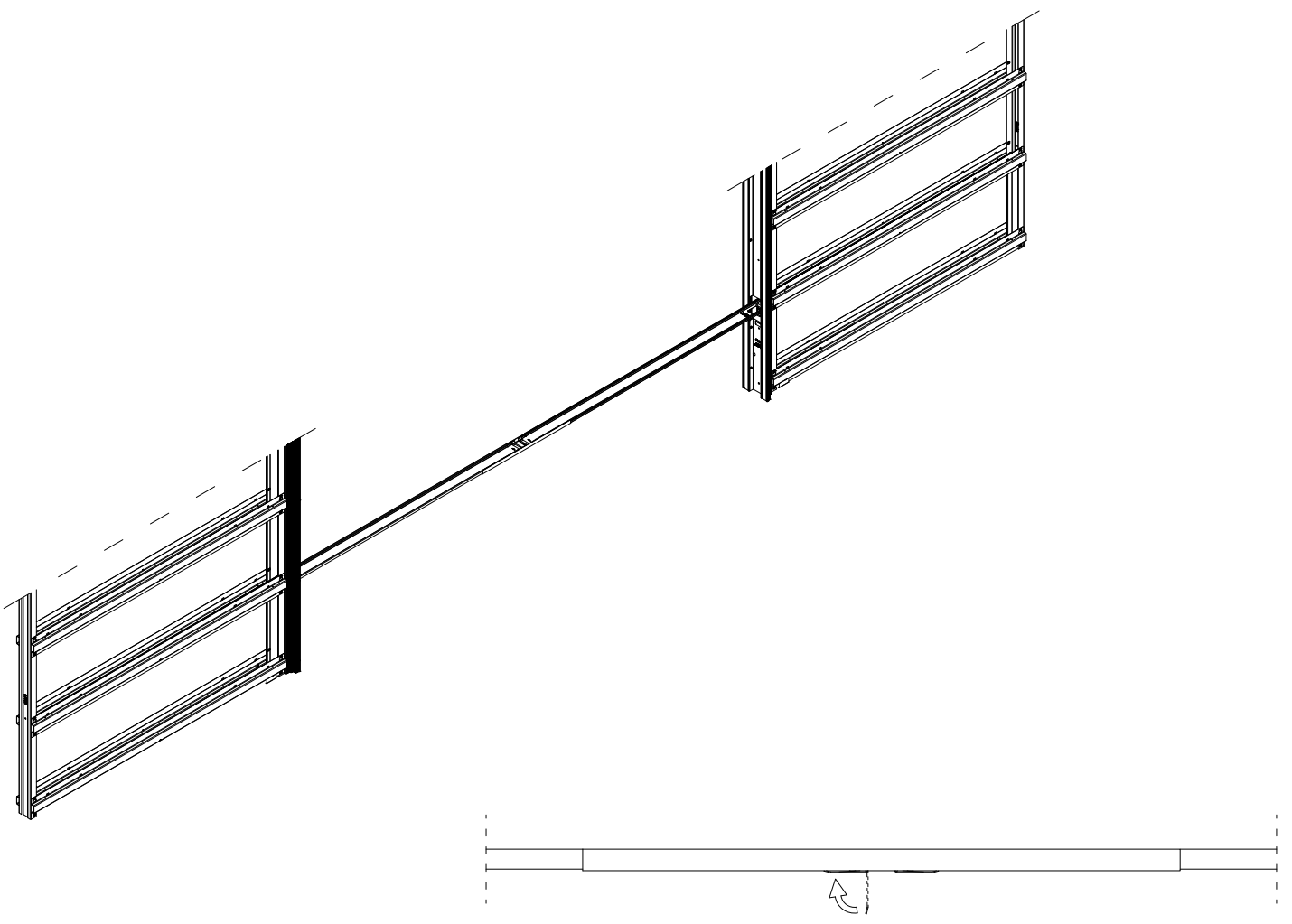
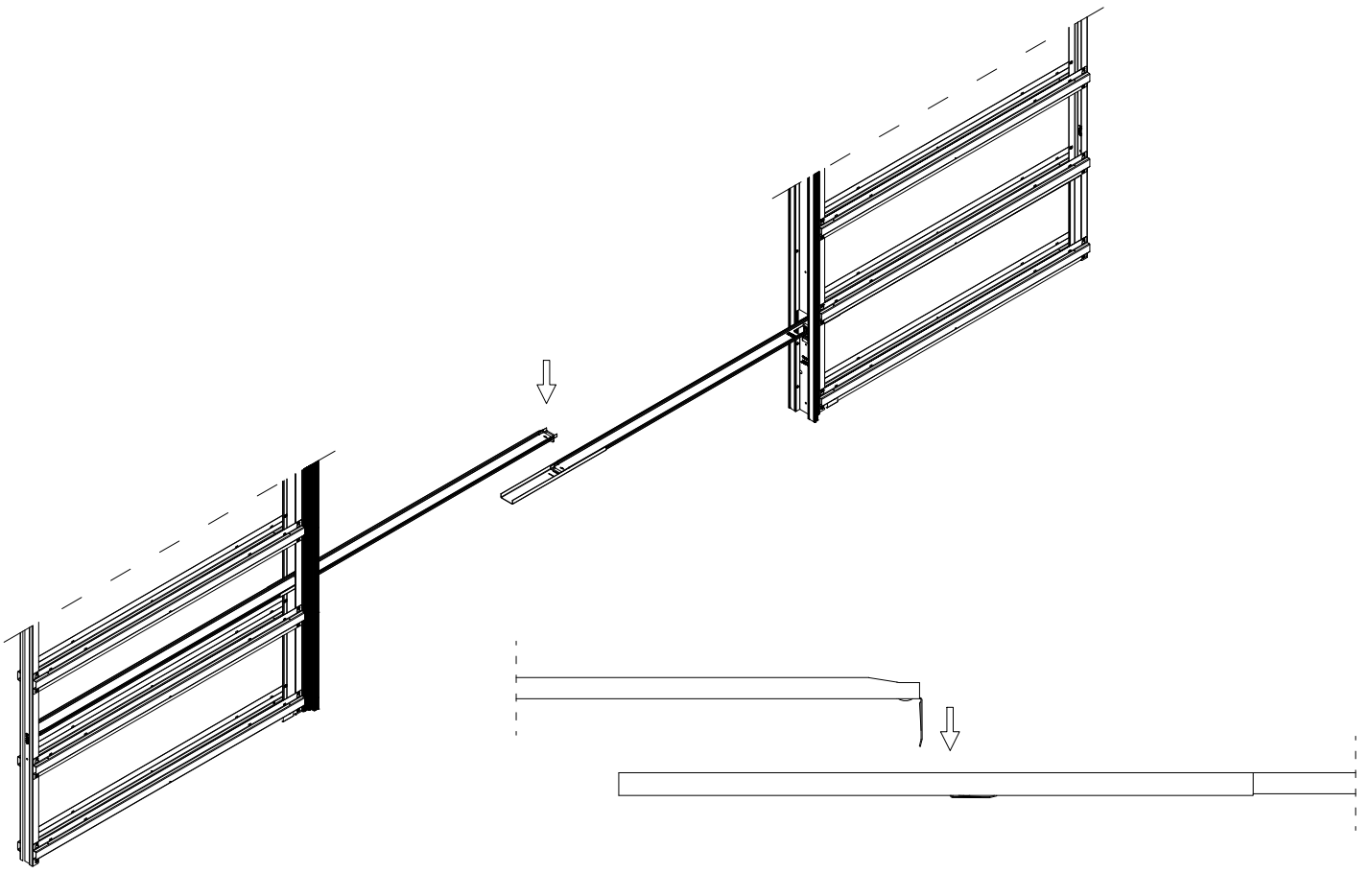



Fix the Alignment Bars together with Screws (k)

Fijar las Barra de Alineación (h y r) con tornillos (k)

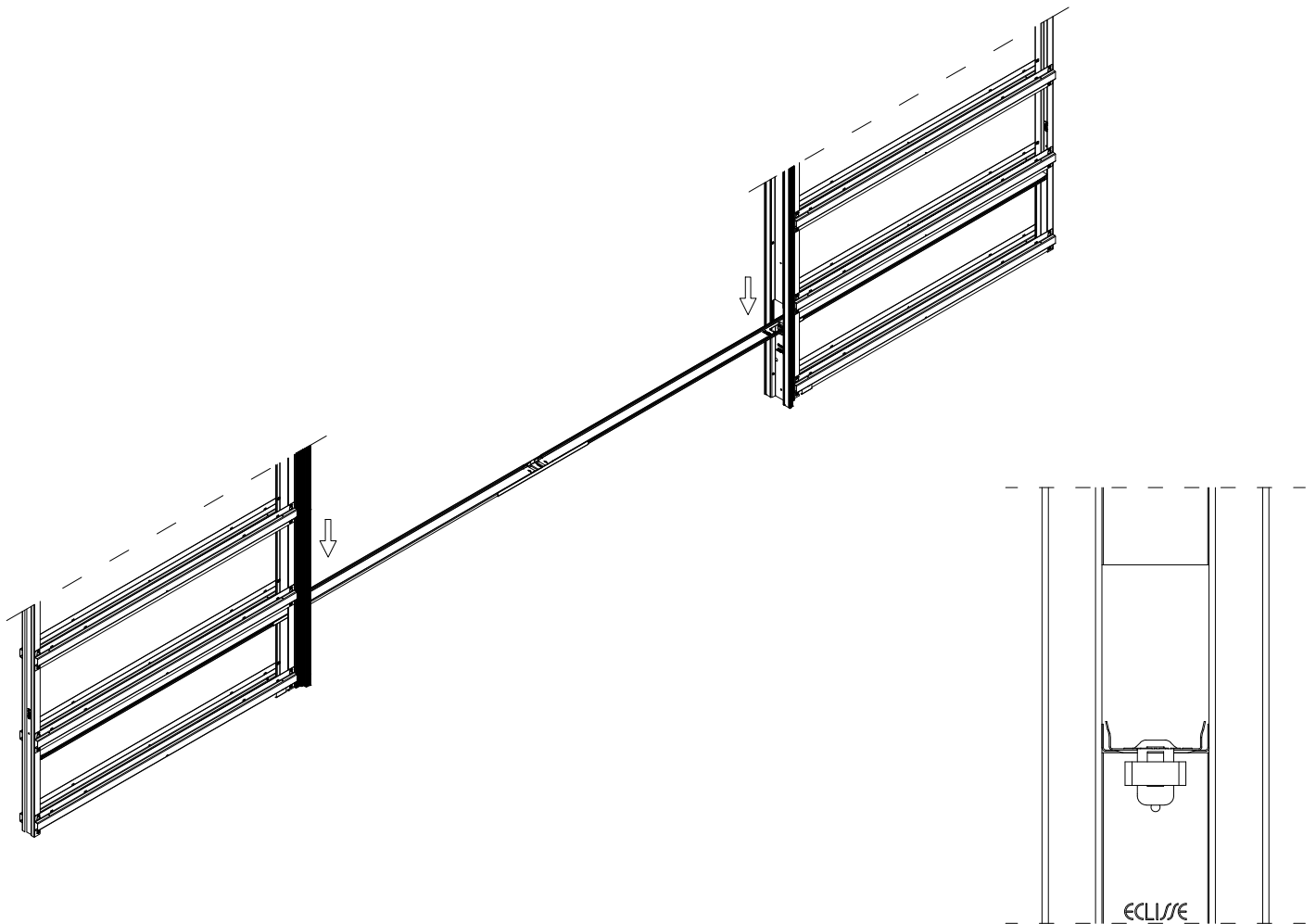
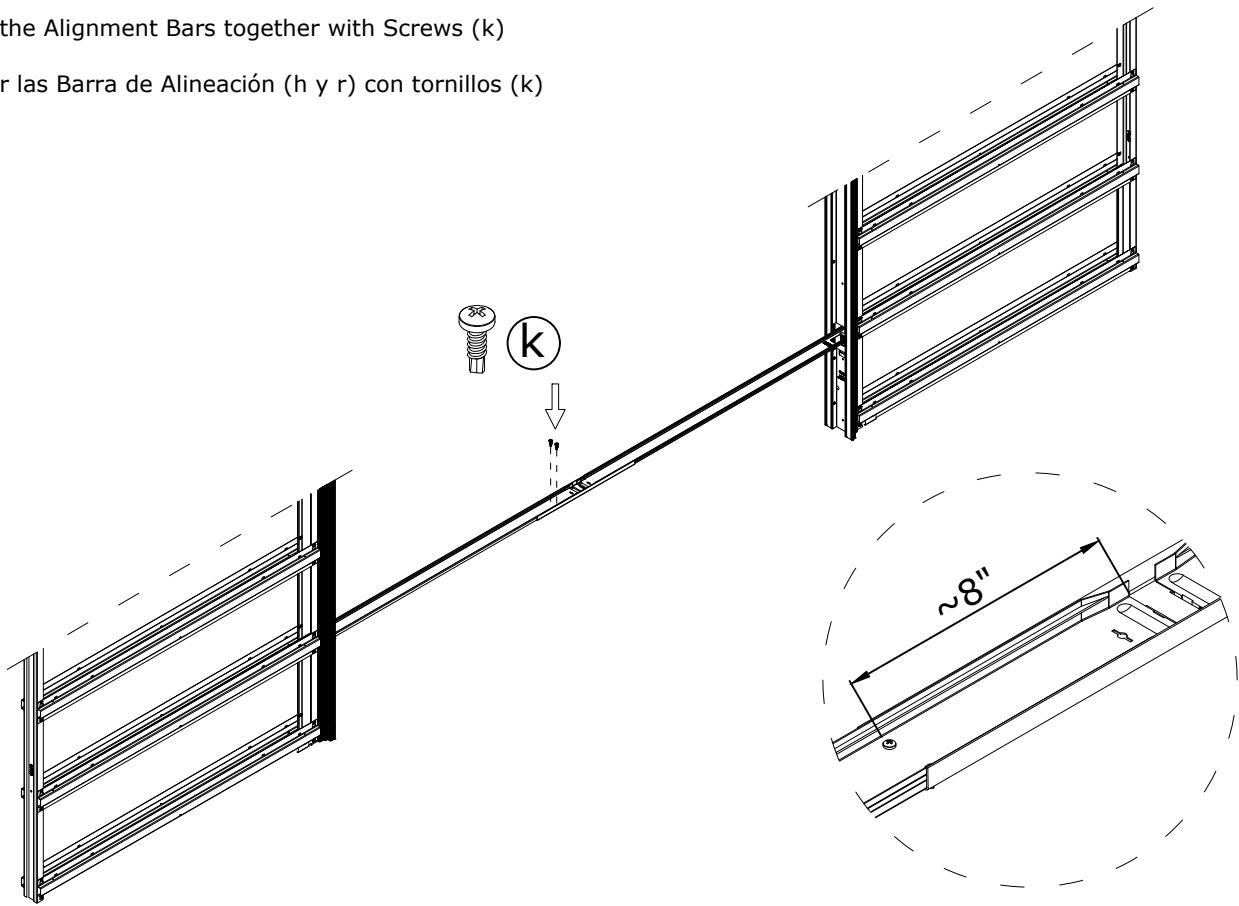

8

Fix the frame to the studwork with screws and make sure its plumb, square and level.

Fijar el marco al montante con tornillos y asegúrese de que esté a plomo, a escuadra y nivelado.

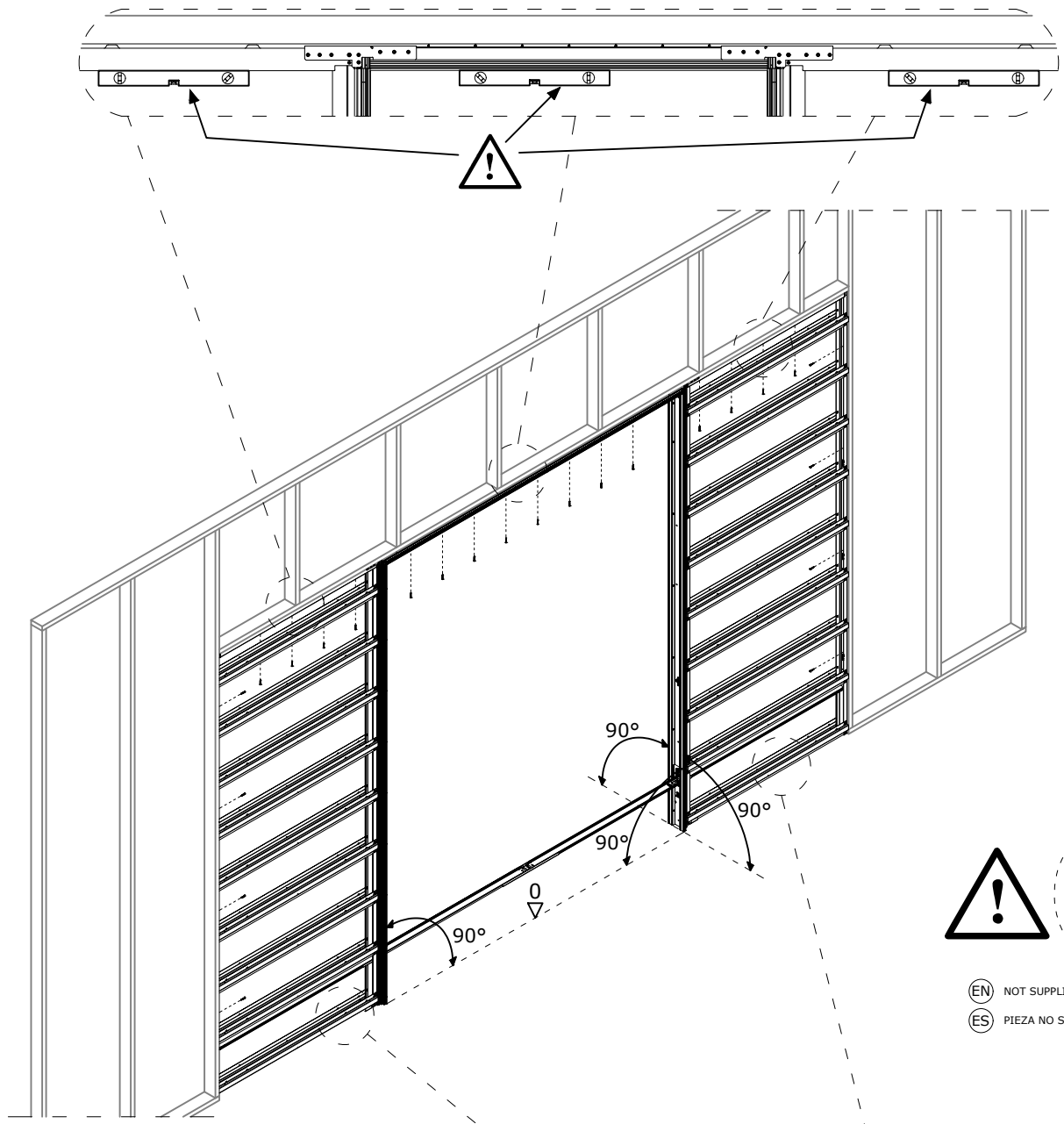

(EN) NOT SUPPLIED  
 (ES) PIEZA NO SUMINISTRADA

**Helpful Tip** - Install Frame at intended finished floor level.

**Consejo de Instalación útil** - Instalar en el nivel del piso terminado.

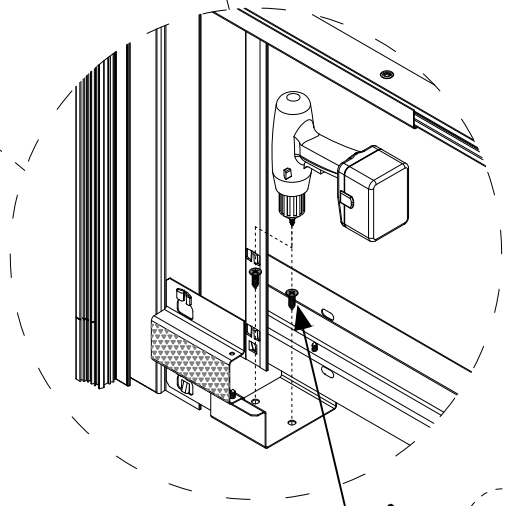
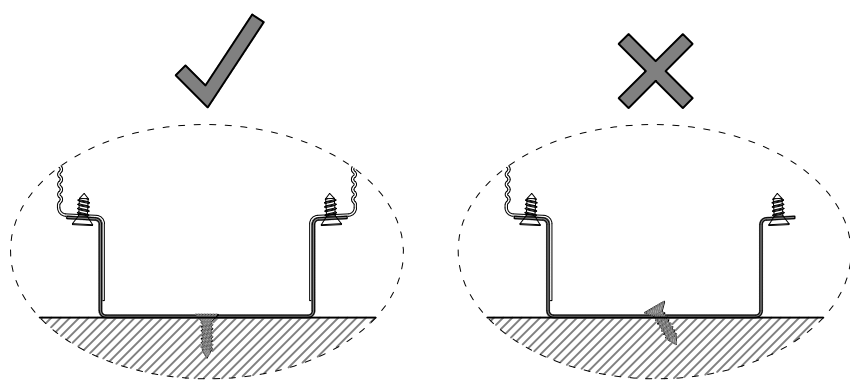

(EN) NOT SUPPLIED  
 (ES) PIEZA NO SUMINISTRADA

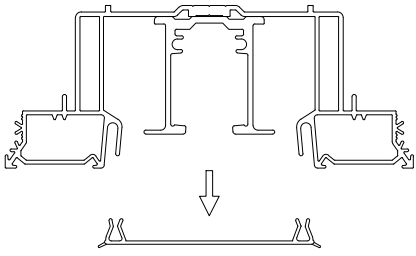

Remove the plastic cover from the Top Beam with Track and slide the adjustable bar inside the track towards the pocket until the holes on the adjustable bar matches the holes of the Pocket Header (d) and make the holes to the studwork. Then slide forward the adjustable bar and put again the plastic cover.

Retire la cubierta de plástico de la Guía Completa de Riel y deslice la barra ajustable dentro del riel hacia el cajón hasta que los orificios de la barra ajustable coincidan con los orificios del Sobrepuerta (d) y haga los orificios para los montantes. Luego deslice hacia adelante la barra ajustable y vuelva a colocar la cubierta de plástico.

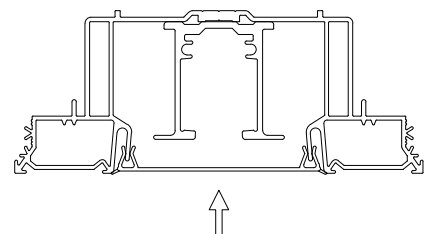
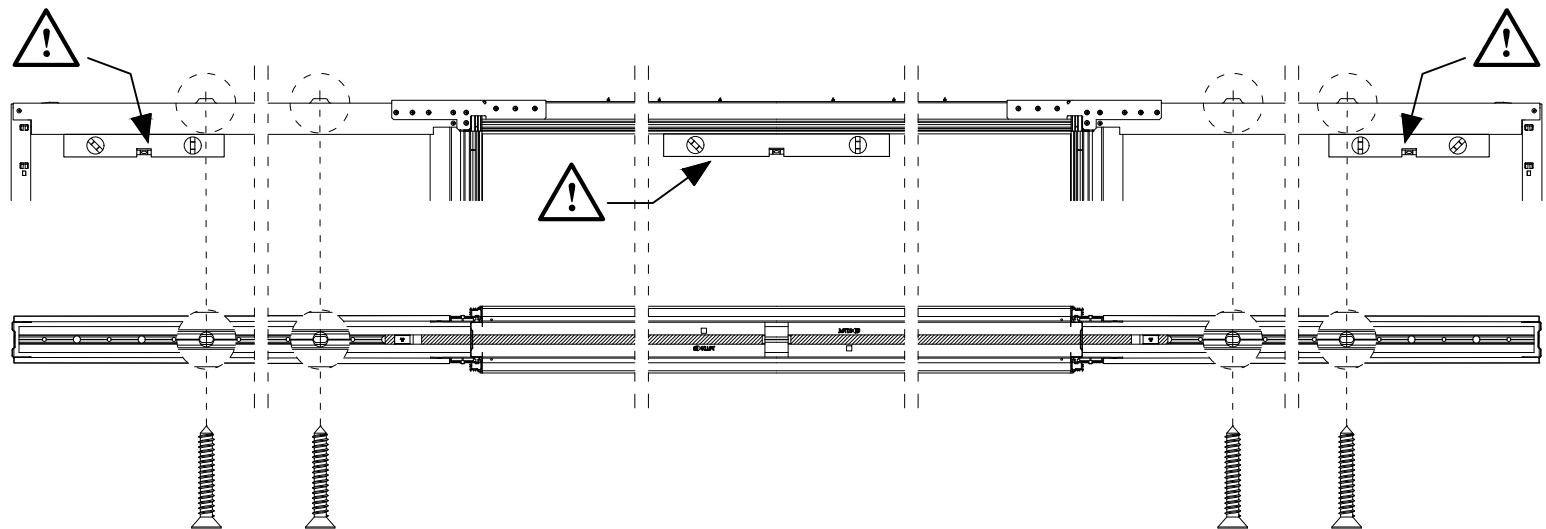
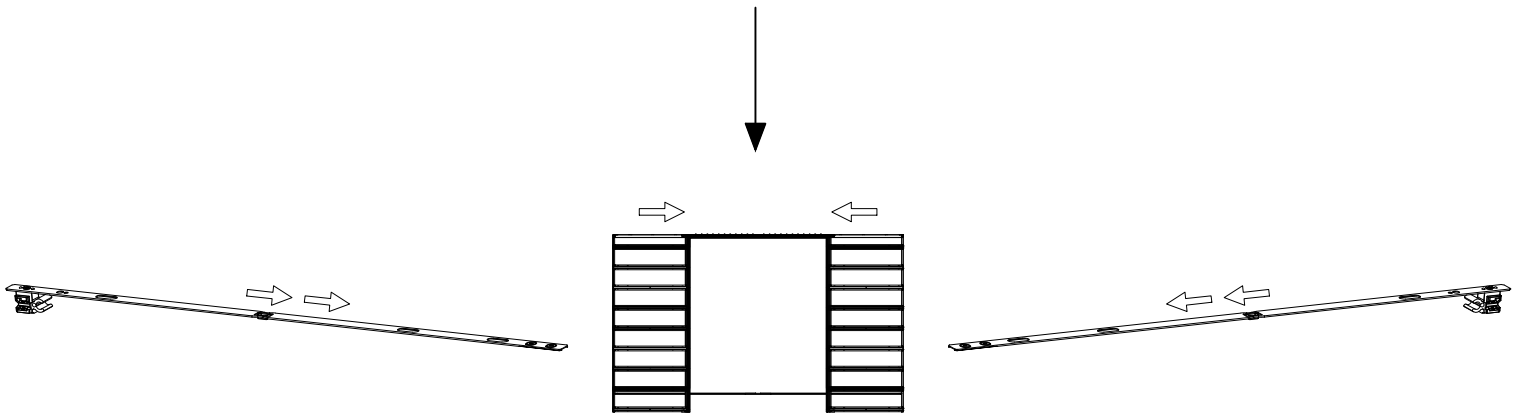
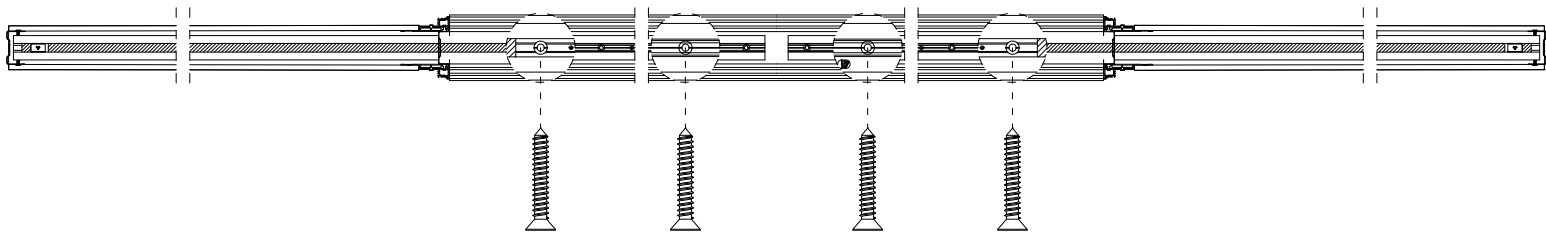
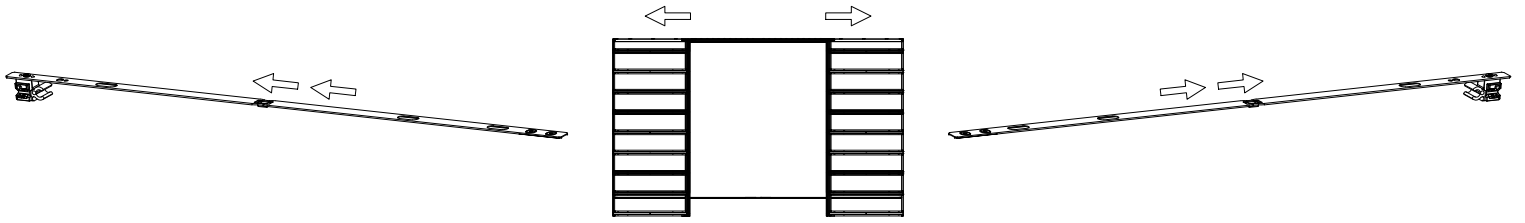

9

Apply the drywall.

Aplicación de las placas de yeso.

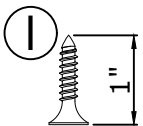
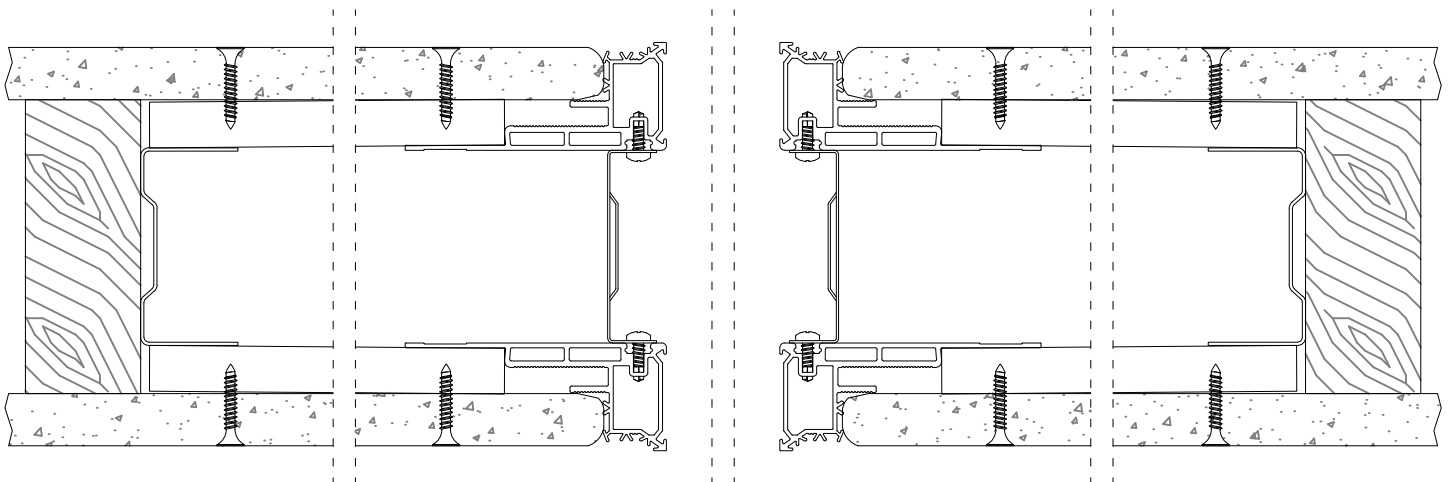
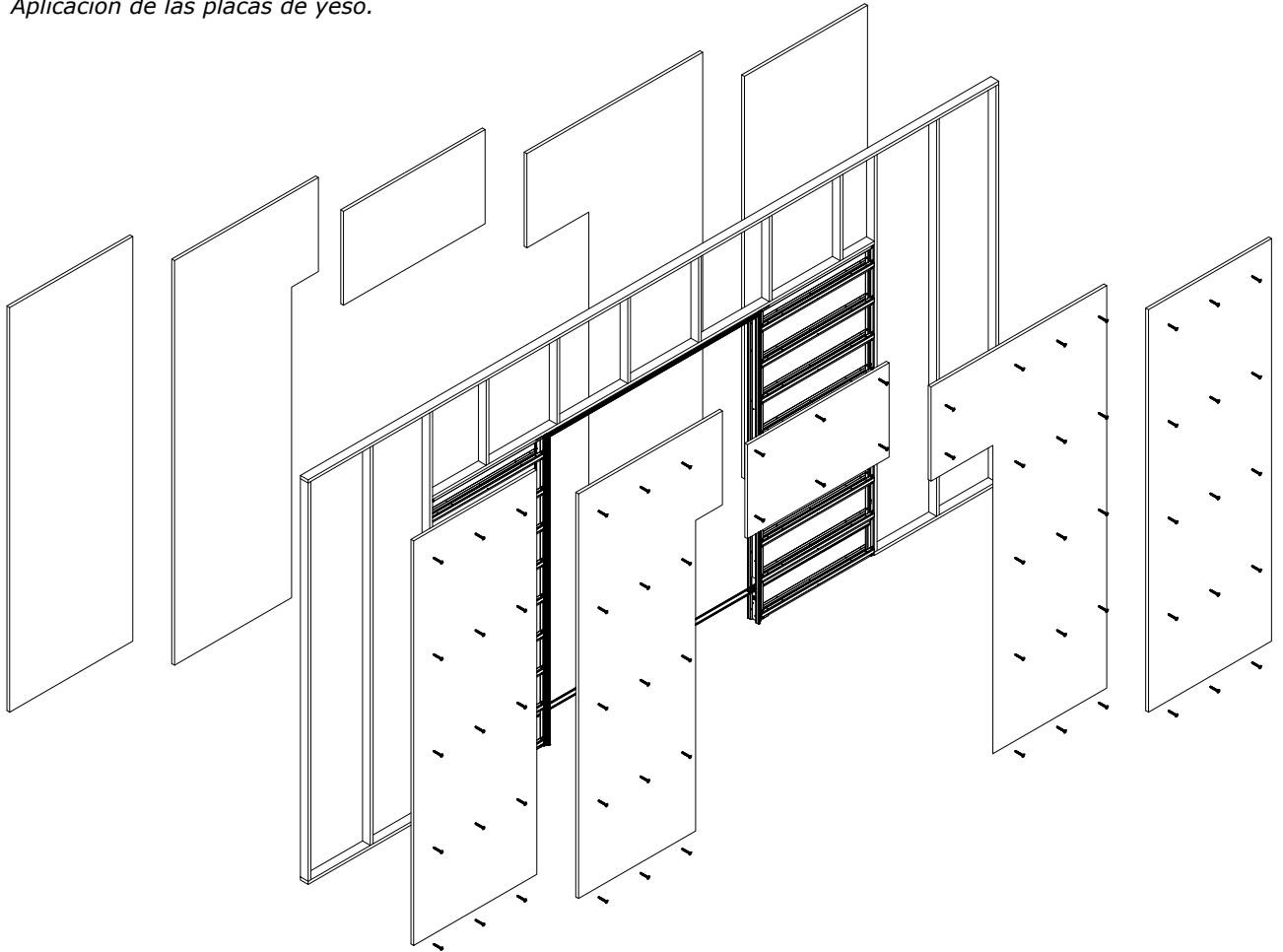

#7x1"  
(3,9x25 mm)

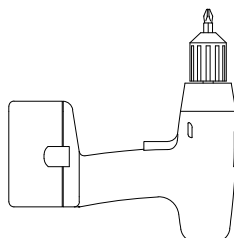

**Warning** – Do not use screws longer than 1" to connect drywall to the horizontal bars, longer screws may damage the door panel.

**Advertencia** – No use tornillos de más de 1" para conectar el cartón yeso a los refuerzos horizontales, los tornillos más largos pueden dañar el panel de la puerta.

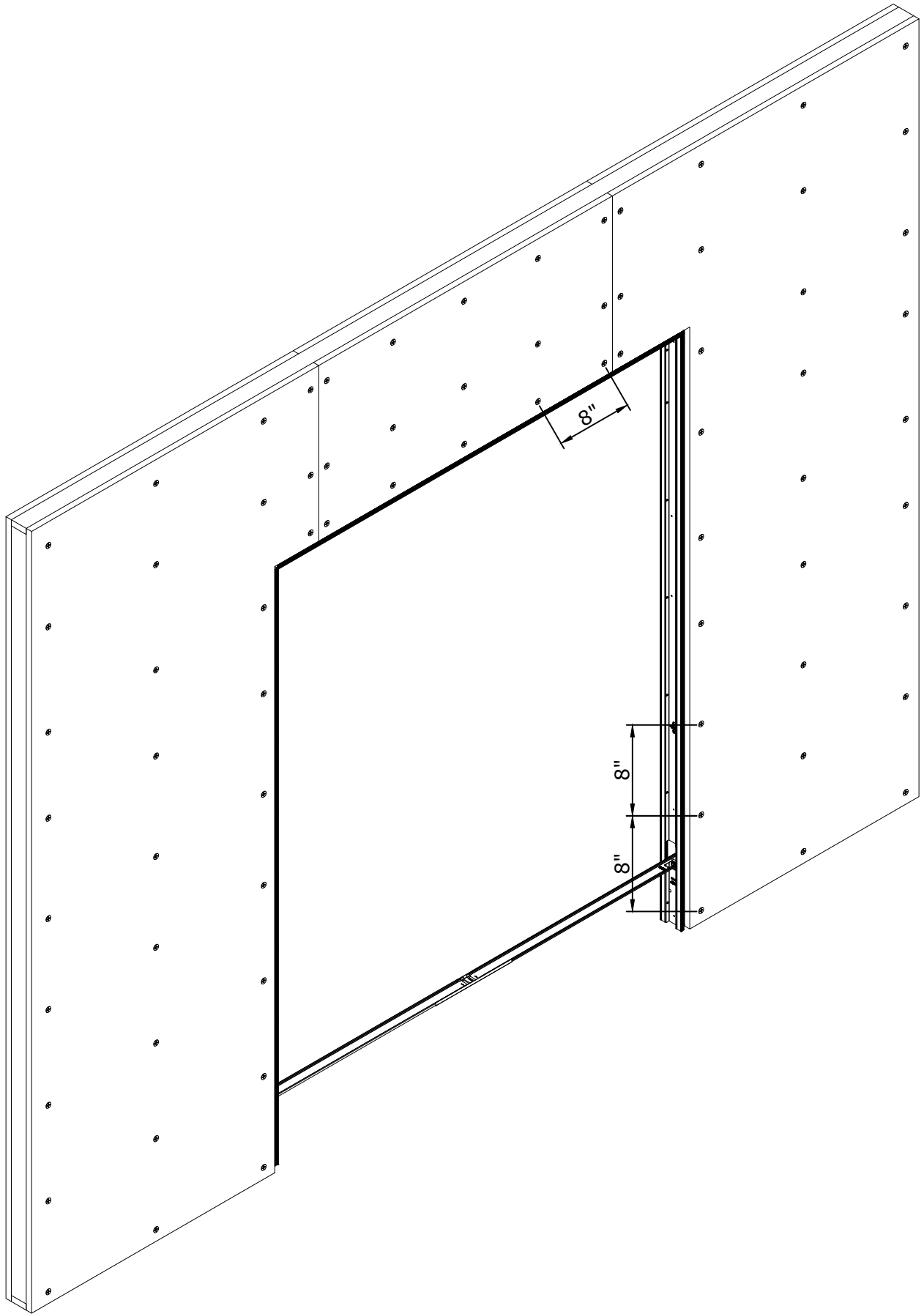

10

Apply the plaster at the edges of the frames as showed on diagram A and B.

*Aplice el yeso en los bordes de los marcos como se muestra en el diagrama A y B.*

(EN) APPLICATION OF PLASTER

(ES) APLICACIÓN DE ESTUCO

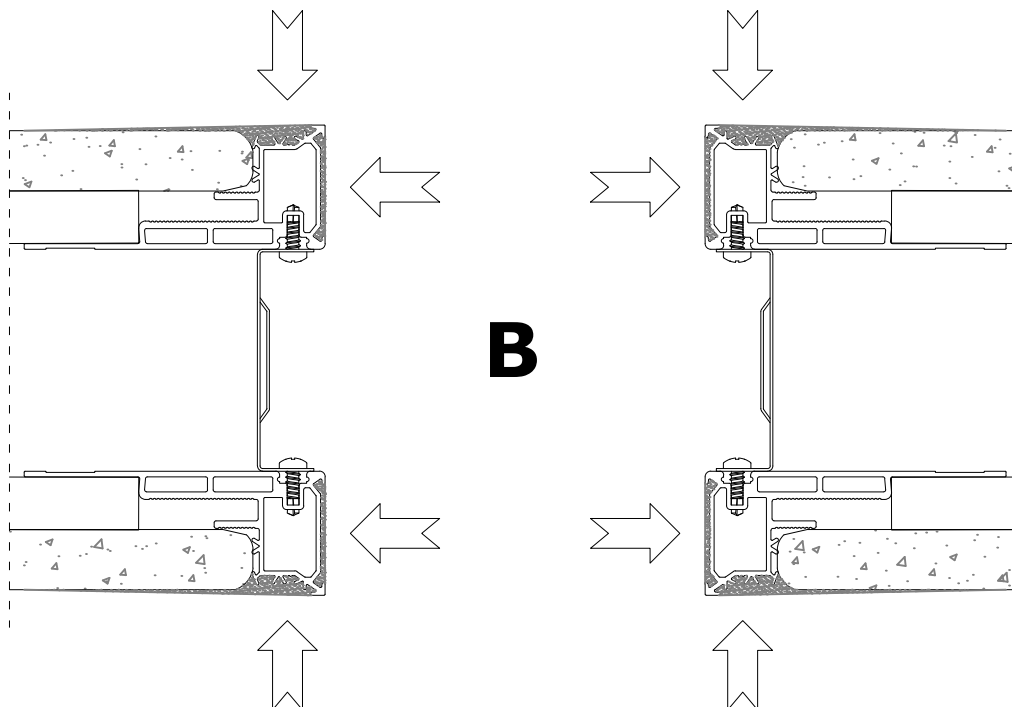
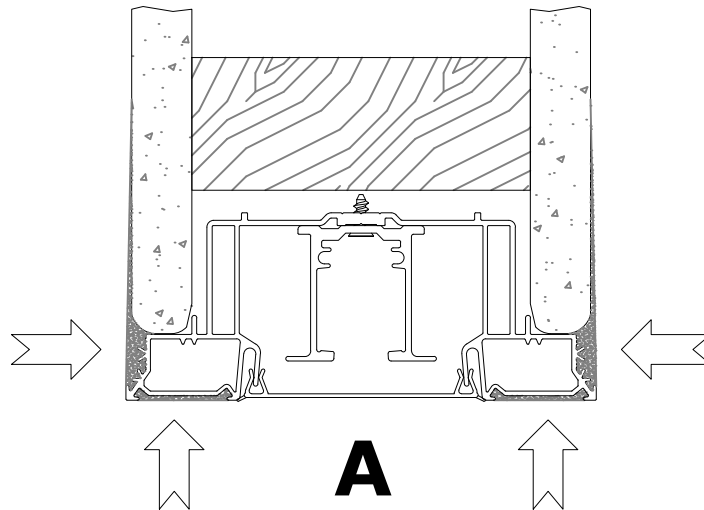
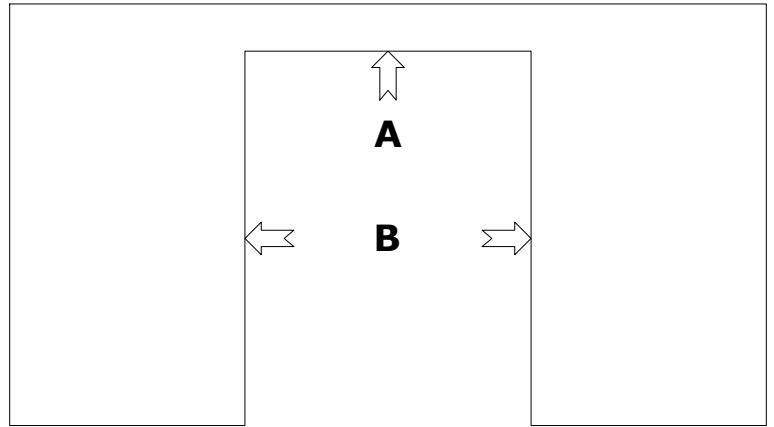



**11**

Remove the Alignment Bar.

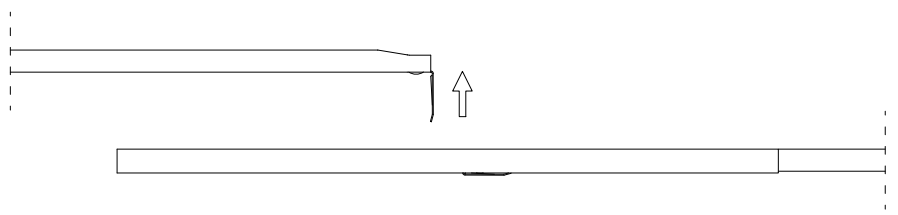
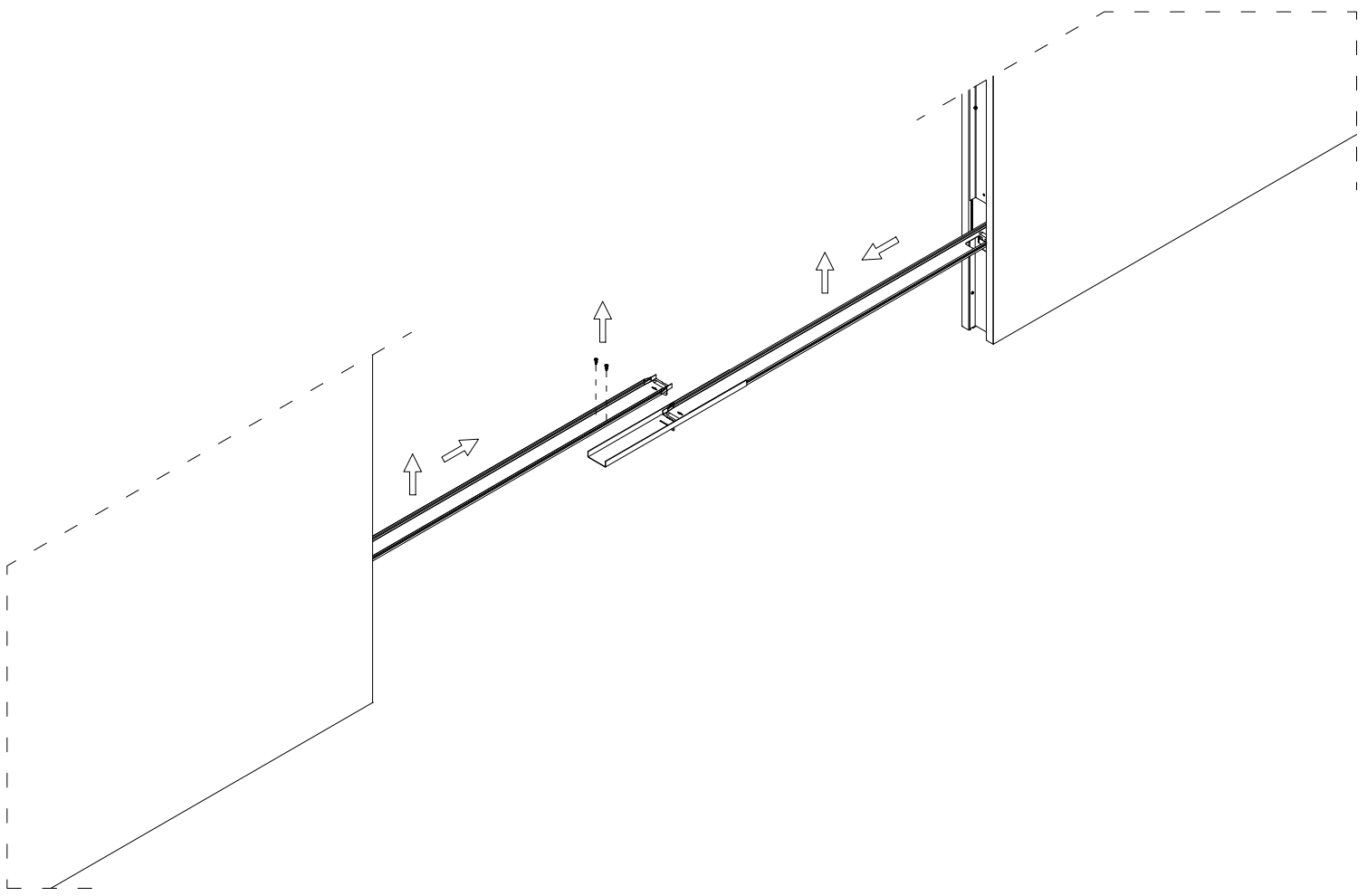
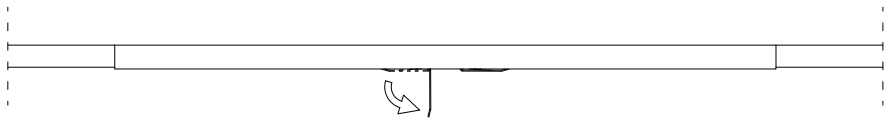
*Quitar la Barra de Alineación.*

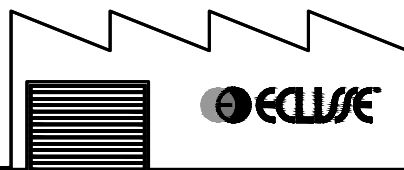
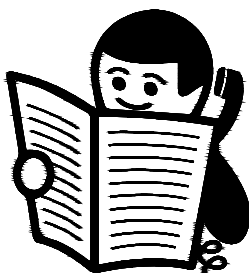
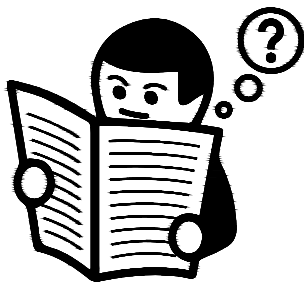



 **ECLISSE NORTH AMERICA LLC** - Tel.:001 800 614 1474 - info@eclissenusa.com - www.eclisse.us

**www.eclisse.us**

