

0521
00

ECLISSE BIAS® DS

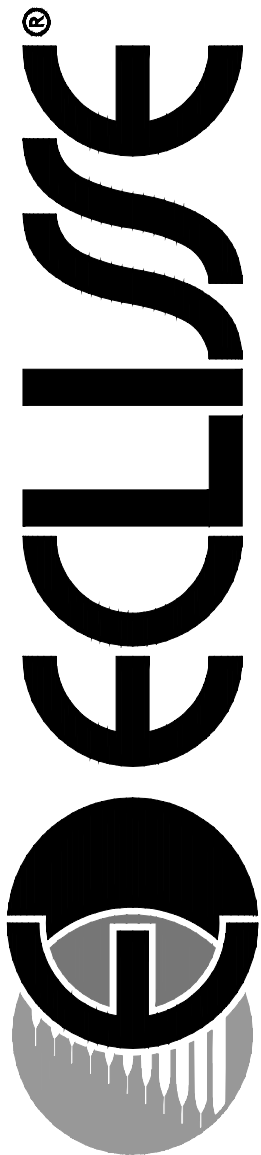
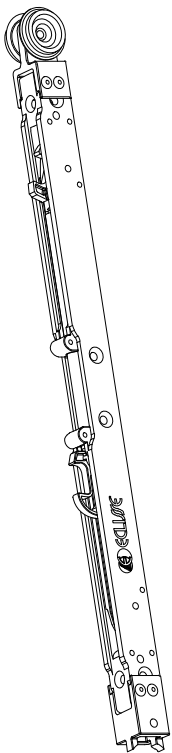

ECLISSE BIAS® DS

Soft Closer - Both Direction

CLASSIC COLLECTION

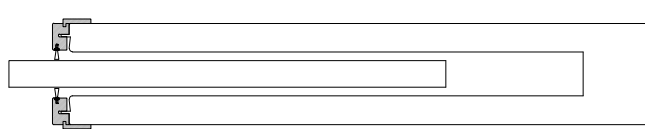
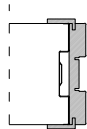
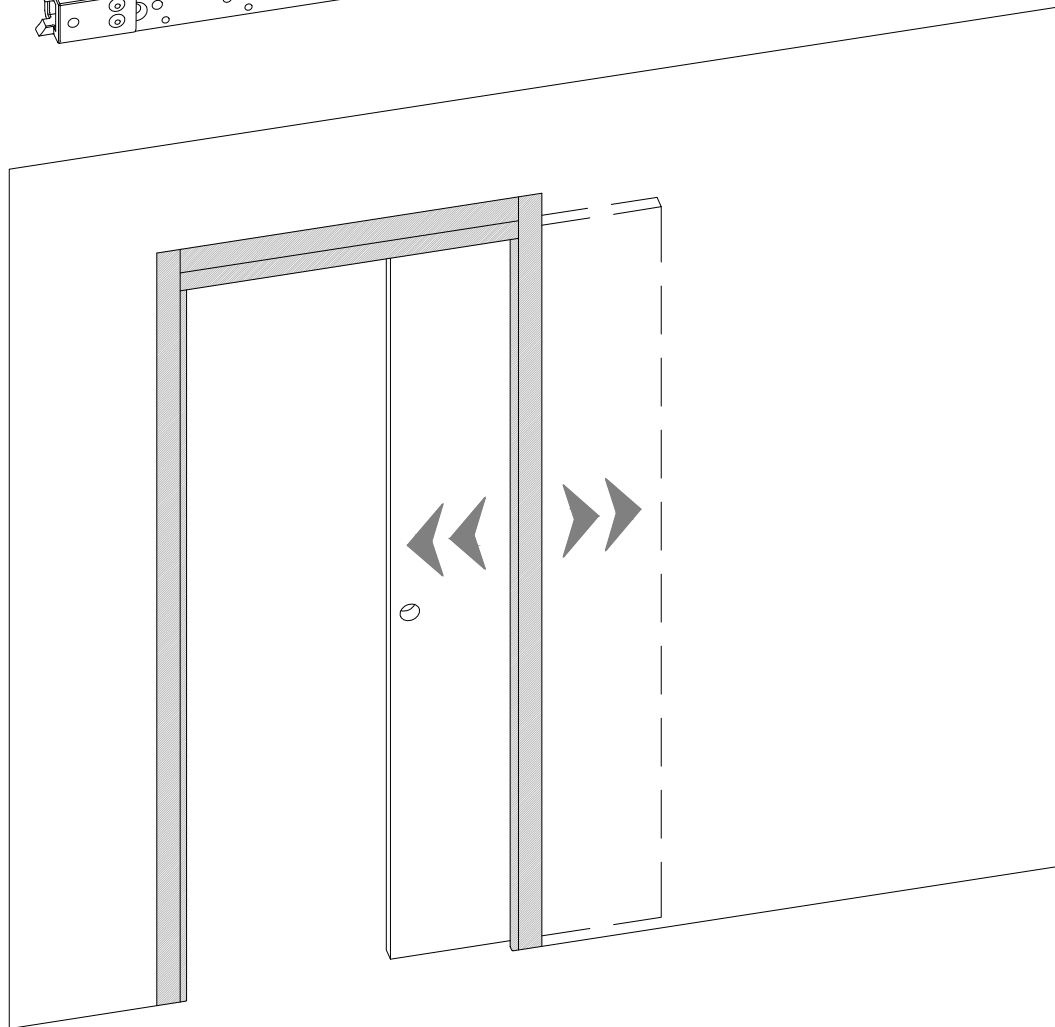
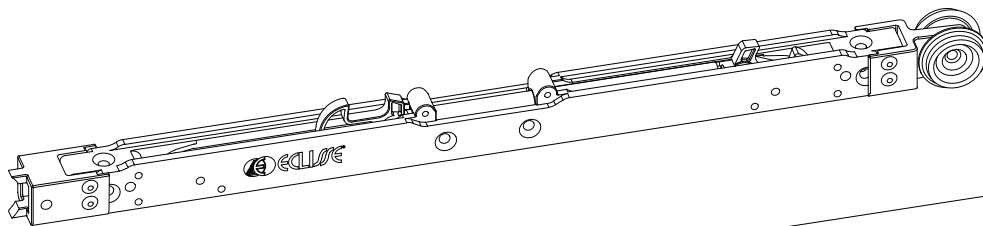

MANDATORY TOOLS
HERRAMIENTAS OBLIGATORIAS PARA EL MONTAJE

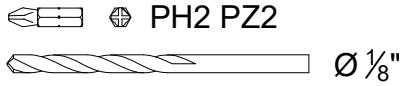
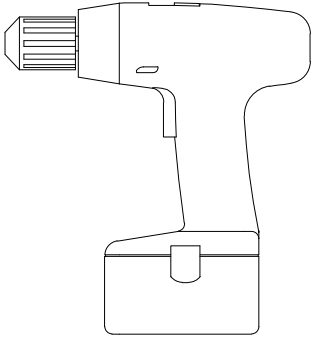

DRILL
DESTORNILLADOR

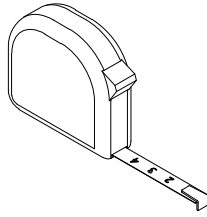

TAPE MEASURE
METRO

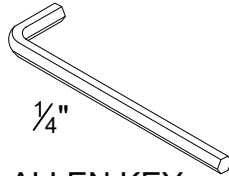

ALLEN KEY
LLAVE ALLEN

EN388

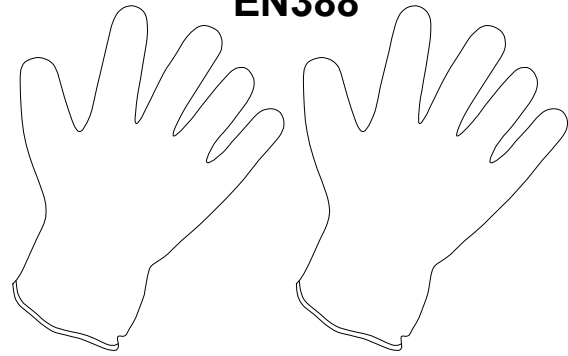

GLOVES
GUANTES

COMPONENTS
COMPONENTES



BIAS-DS MECHANISM
MECANISMO BIAS-DS

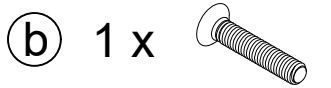

SCREW
TORNILLO

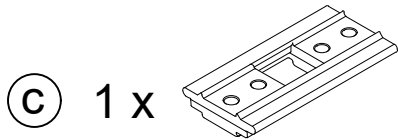

ACTIVATION BRACKET
SOPORTE DE ACTIVACIÓN

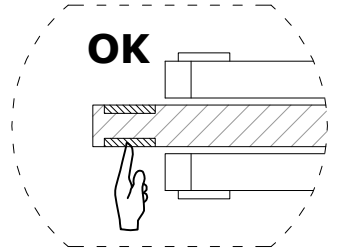
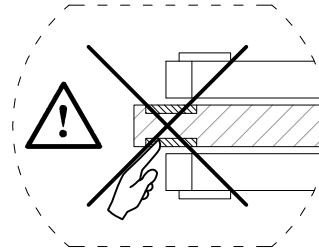
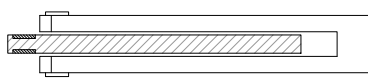

EN WARNING: All sliding doors, if unprofessionally and recklessly handled, can be dangerous also depending on the size and characteristics of the panel and of the material of which is made. For safety reasons, our counterframes are equipped with adjustable door catch. In order to avoid the risk of injury it is absolutely necessary to install it, taking care to stop the door, so that the handle stays completely on sight and the hand, while holding and using the handle, and based on the sizes and characteristics of the latter, can never come into contact with the edge of the counterframe or with projecting and/or reentering accessories, decorations or other characteristics of the door panel.
In the event of non-observance of these warnings, which must be communicated by the installer and/or vendor to the end user, Eclipse Srl disclaims all liability for any injuries.

ES ATENCIÓN: El uso imprudente o inadecuado de las puertas correderas puede representar peligro en función de las dimensiones y características del panel así como del material del que se compone. Por razones de seguridad, nuestros contramarcos cuentan con un tope final de carrera ajustable. Para evitar cualquier riesgo de lesiones, es totalmente necesario que tras la instalación la hoja llegue al tope dejando el tirador totalmente a la vista y que la mano, en el momento de empujar y utilizar el tirador y en función de las dimensiones y características de éste, no pueda entrar en contacto en ningún caso con el borde del contramarco ni con los accesorios, decoraciones u otros elementos, salientes y/o entrantes, del panel puerta. En caso de violación de dichas advertencias, el usuario final deberá ser informado por el instalador y/o el proveedor, quedando Eclipse srl exenta de toda responsabilidad derivada de eventuales lesiones.

1

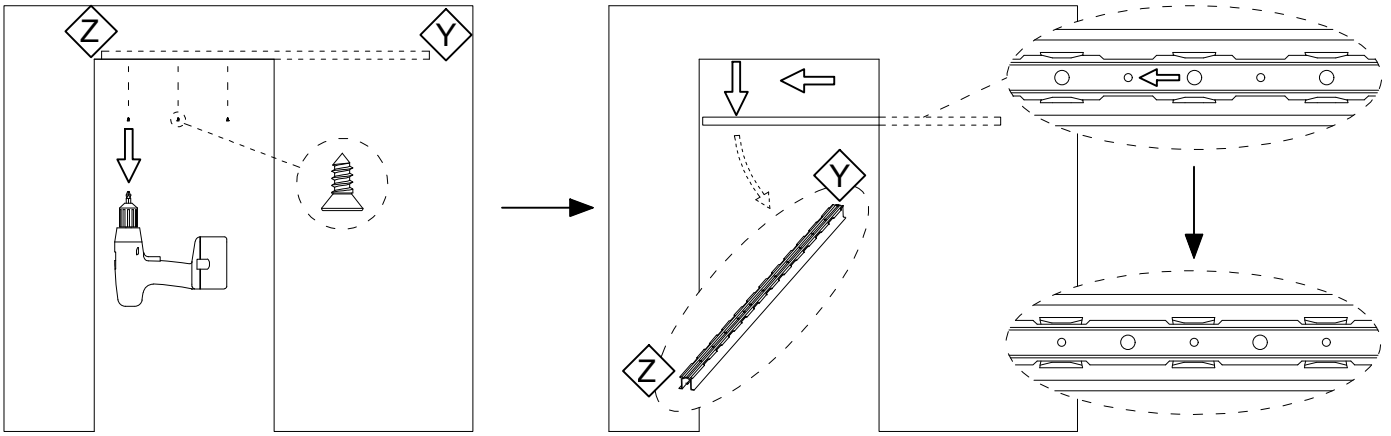

Remove track from the pocket unit by removing the small screws holding the track to the header across the opening. Slide the track to one side and it will drop out.
 NOTE: Please store these screws safely.

*Retire el riel del contramarco quitando los pequeños tornillos que sujetan el riel al travesaño a través de la abertura.
 Deslice el riel hacia un lado y se caerá.
 NOTA: Guarde estos tornillos de forma segura.*

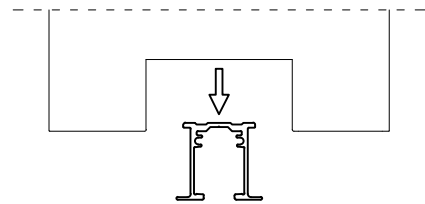

ALTERNATIVELY

If installing BIAS-DS with New Frame Kit: Before assembly the new Frame Kit, insert the BIAS-DS into the track with the runners (as showed in the next steps), then assemble the frame kit, this will save you time and not require the track to be removed later.

Si se instala el BIAS-DS junto con el Contramarco: Antes de ensamblar el nuevo contramarco, inserte el BIAS-DS en el riel con las guías (como se muestra en los siguientes puntos), esto le ahorrará tiempo y no requerirá que retire el riel más.

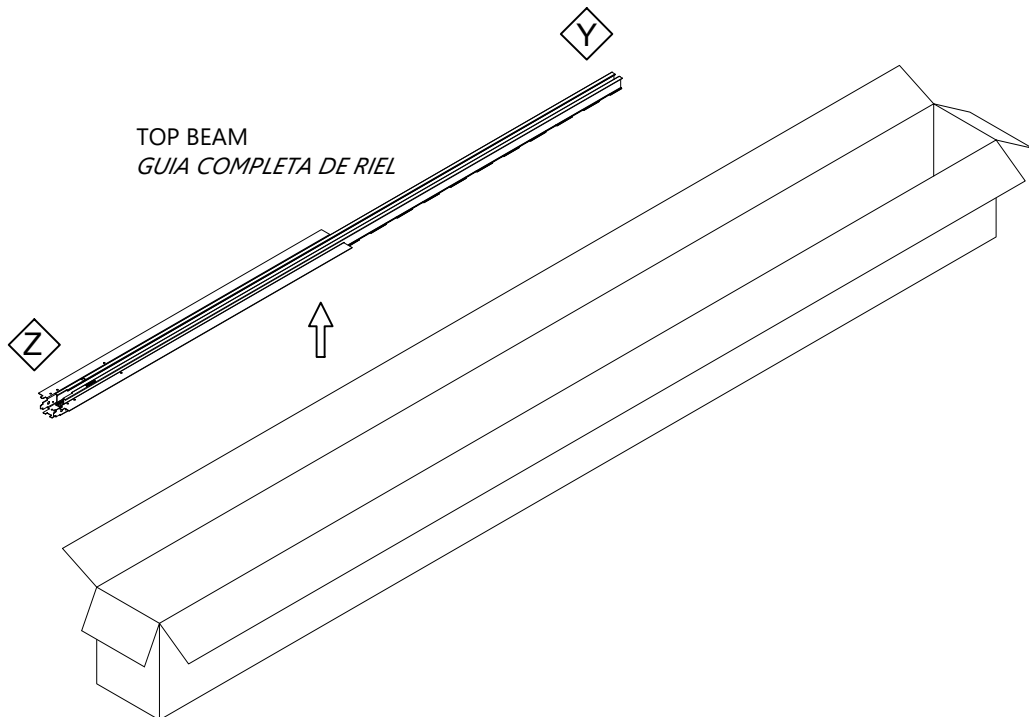

2

Remove both adjustable door stops from the track and throw them away.

Retire ambos topes ajustables del riel y deséchelos.

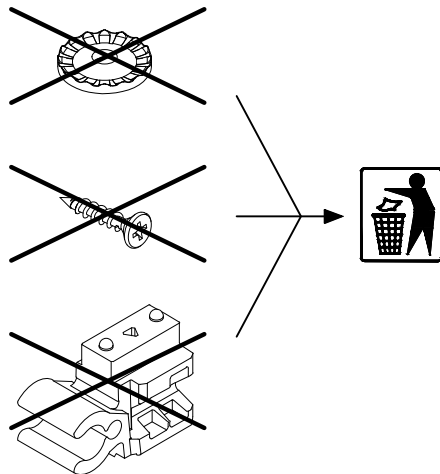
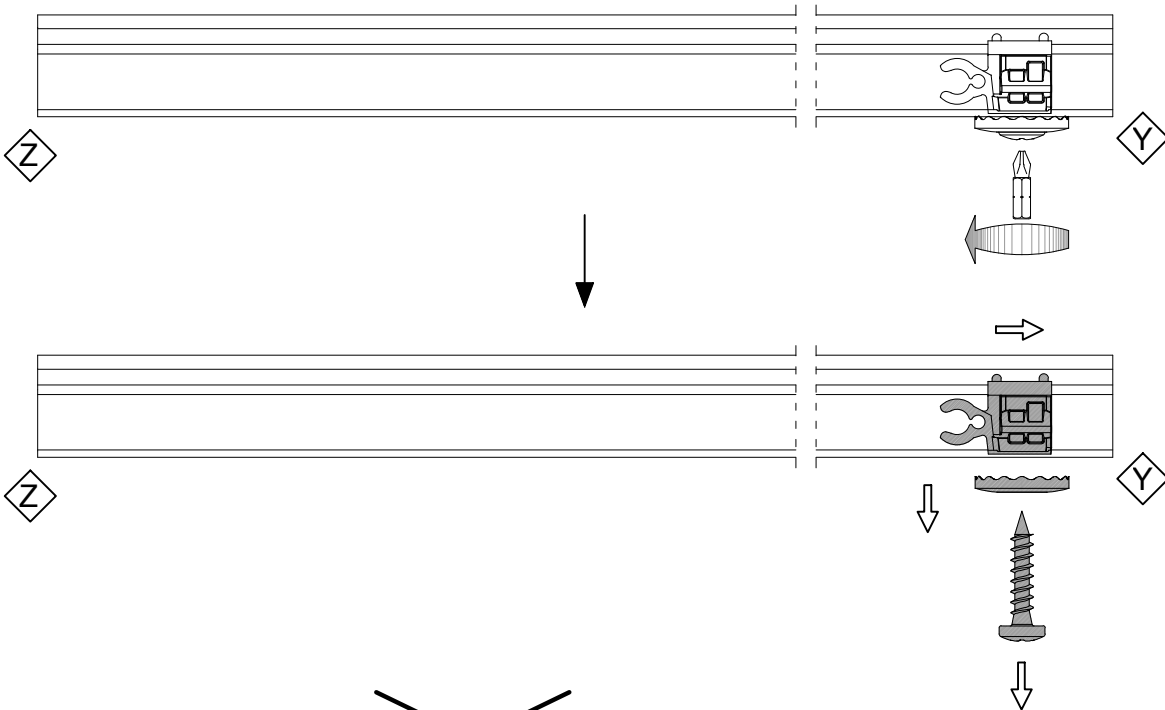
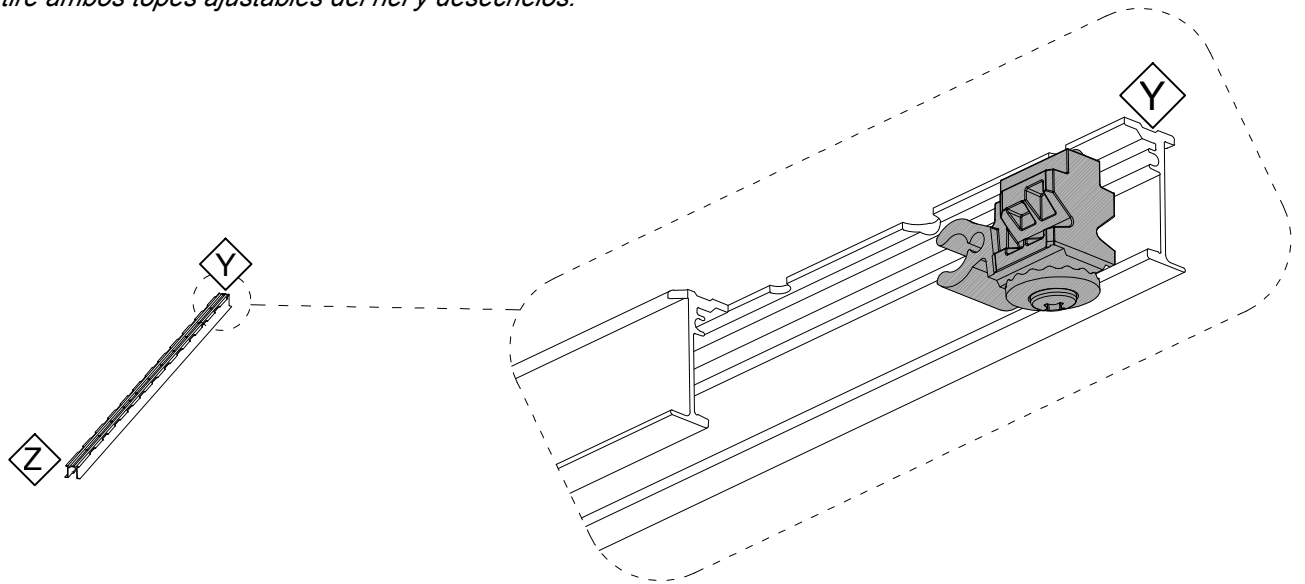

3

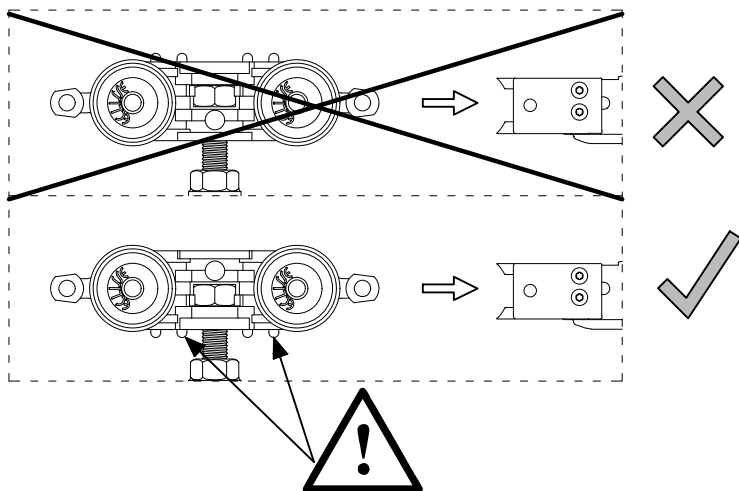

Take careful note of the nibs on the runners, these are to face downwards.

Tome nota de las puntas de los carros de deslizamiento, estos son para mirar hacia abajo.

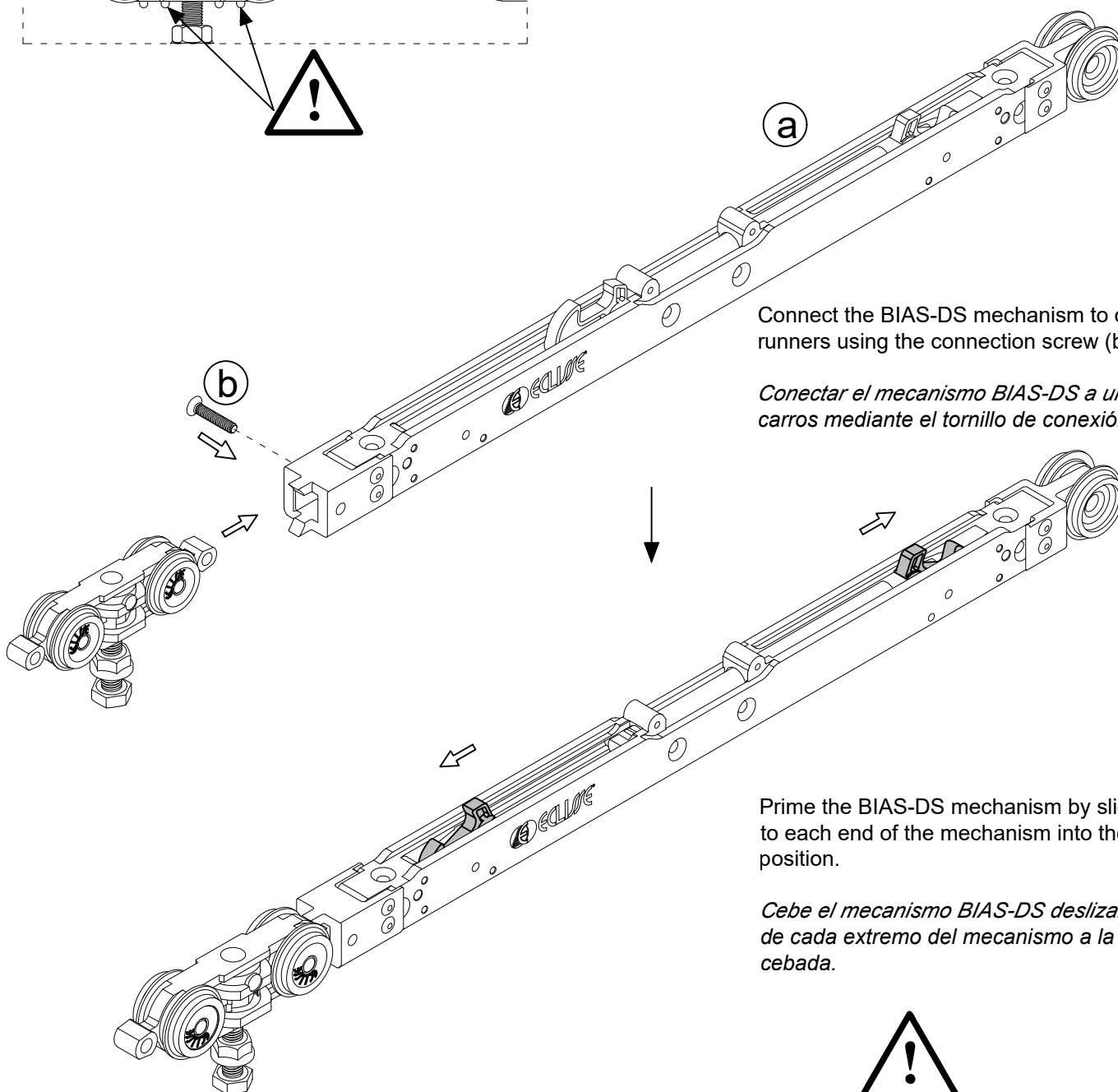

Connect the BIAS-DS mechanism to one of the runners using the connection screw (b).

Conectar el mecanismo BIAS-DS a una de las carros mediante el tornillo de conexión (b).

Prime the BIAS-DS mechanism by sliding the claws to each end of the mechanism into the primed position.

Cebe el mecanismo BIAS-DS deslizando las garras de cada extremo del mecanismo a la posición cebada.

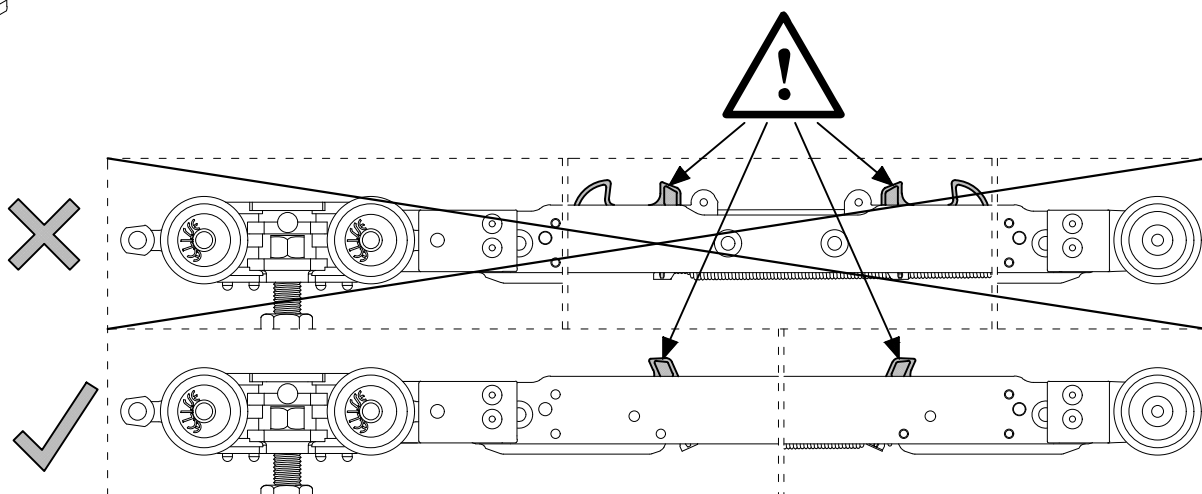

4

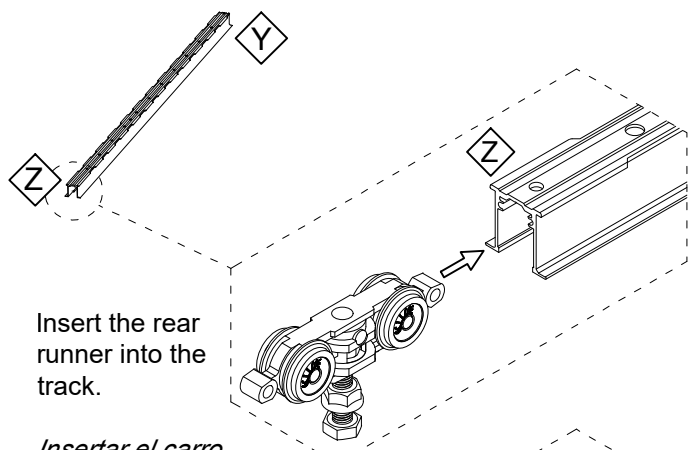
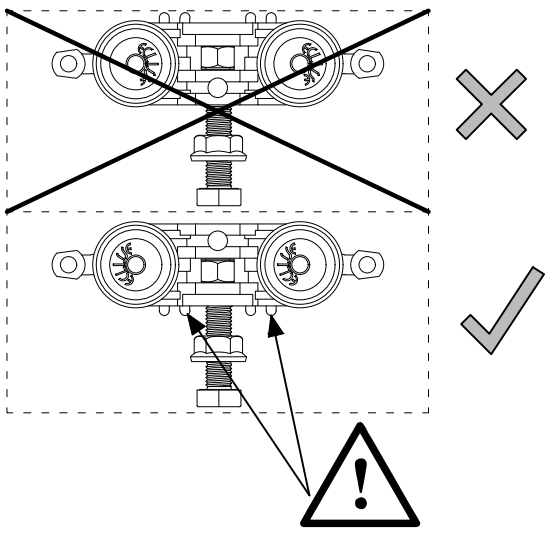

Insert the rear runner into the track.

Insertar el carro de deslizamiento trasero en el riel.

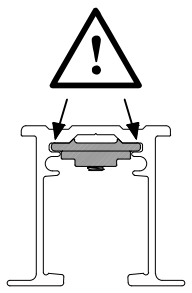
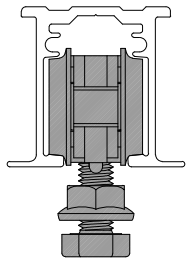

Insert the activation bracket (C) into the upper slot of the track. Take care to ensure the bracket is inserted in the correct orientation as shown.

Insertar el soporte de activación (C) en la ranura superior del riel. Asegúrese de que el soporte se inserte en la orientación correcta, como se muestra.

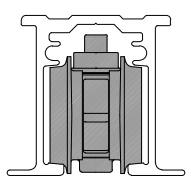
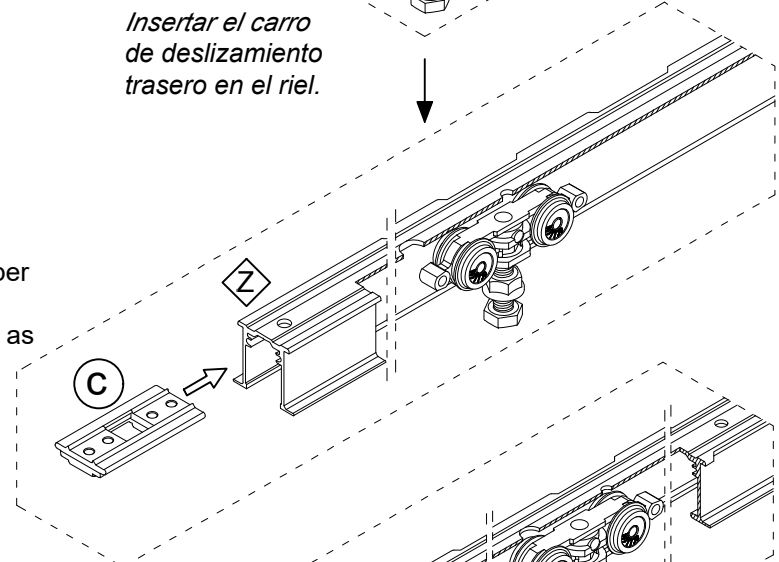

Next insert the BIAS DS mechanism and runner assembly into the track (BIAS DS first).

A continuación, insertar el mecanismo BIAS DS y el carro de deslizamiento en el riel (BIAS DS primero).

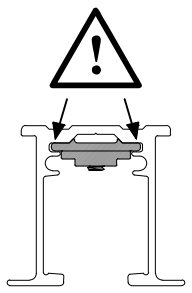
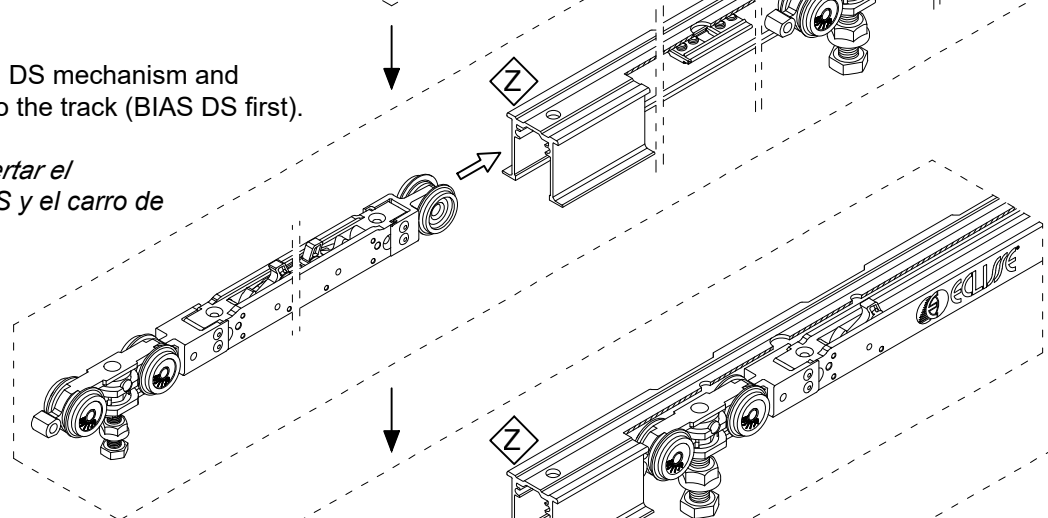

Insert the activation bracket (C) into the upper slot of the track. Take care to ensure the bracket is inserted in the correct orientation as shown.

Insertar el soporte de activación (C) en la ranura superior del riel. Asegúrese de que el soporte se inserte en la orientación correcta, como se muestra.

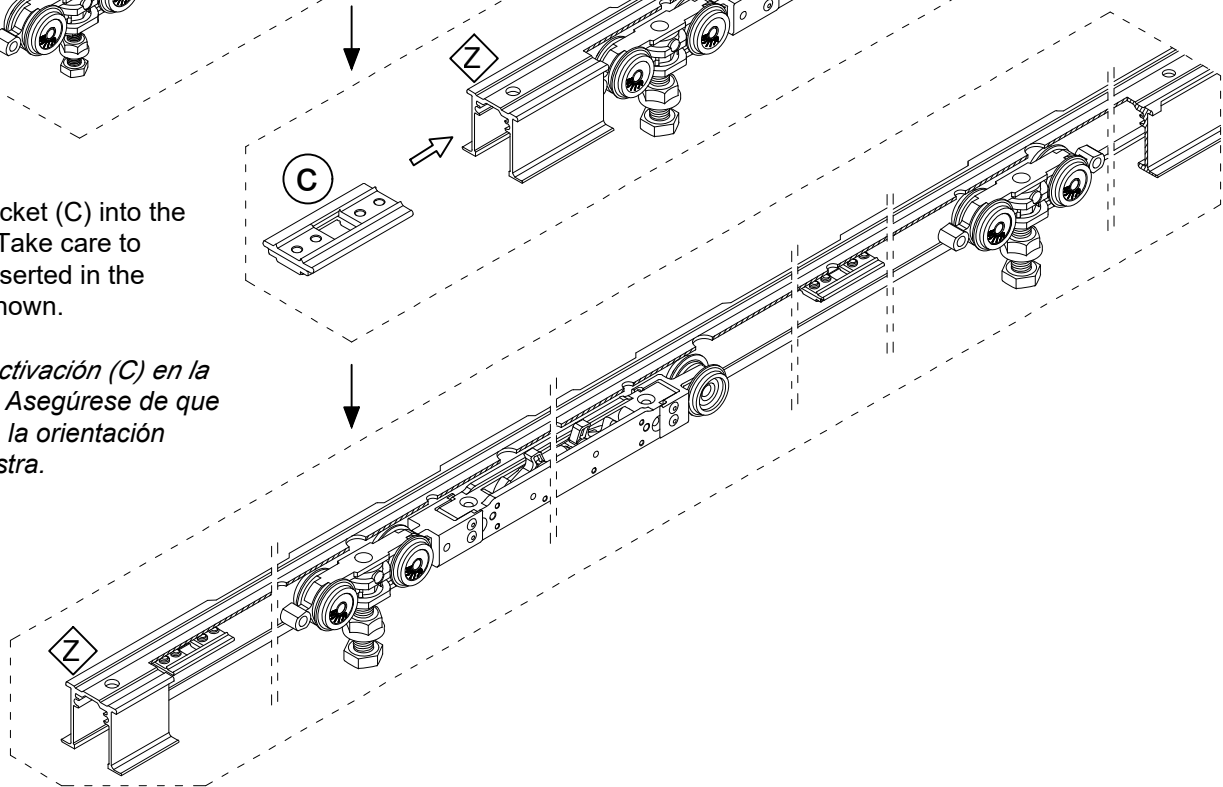

5

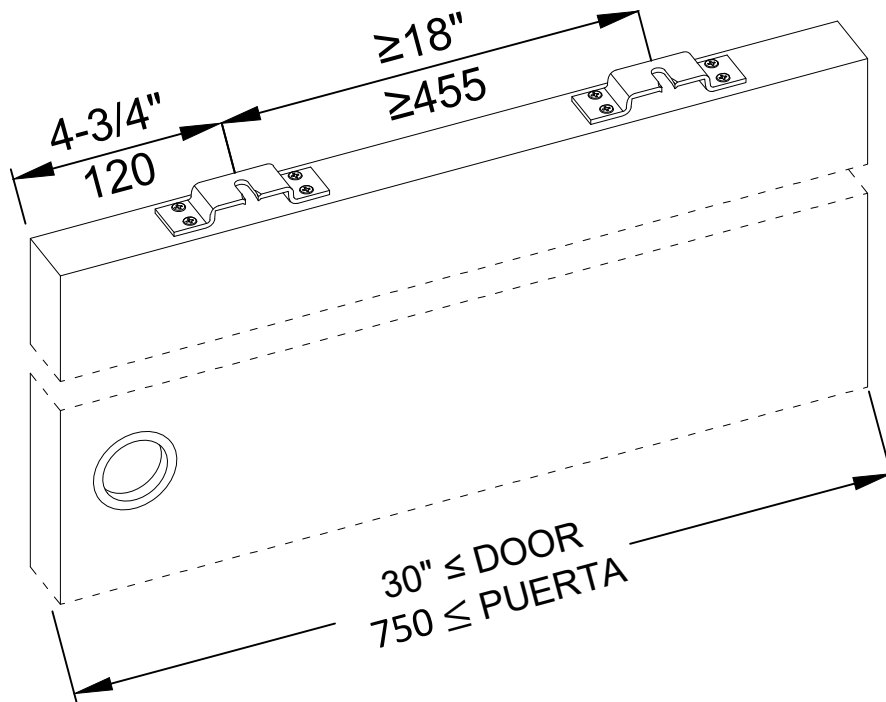

For doors between 24" & 28" wide - reposition the brackets on the door as shown.

Para puertas de entre 24" y 28" de ancho, vuelva a colocar los soportes en la puerta como se muestra.

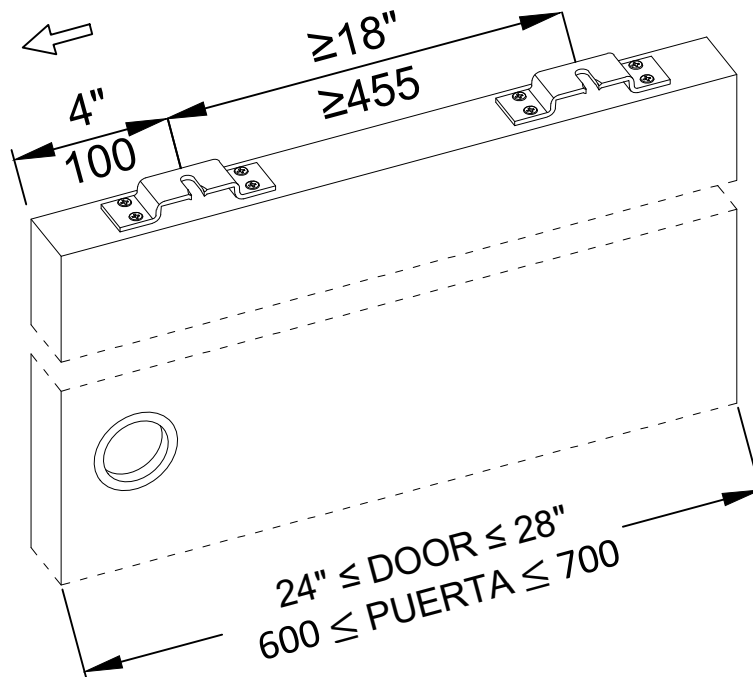

6

Set the activation bracket (c) into place. Ensure all 4 grub screws are tight to prevent movement.

Coloque el soporte de activación (c). Asegúrese de que los 4 tornillos prisioneros estén apretados para evitar el movimiento.

single door puerta única

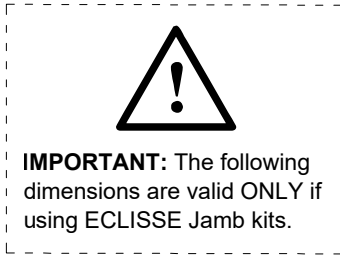
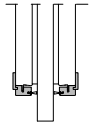

DOORS = 24" - 28"
 For wooden doors:
G = 8-7/8"
 For frameless glass doors:
G = 9-3/8"

DOORS = 30" or more
 For wooden doors:
G = 9-5/8"
 For frameless glass doors:
G = 10-1/8"

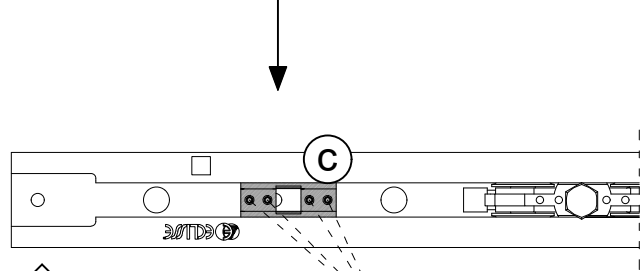
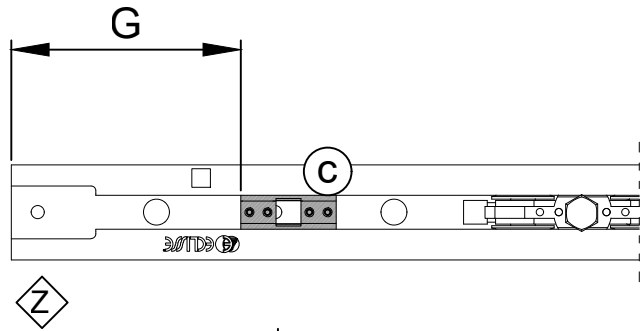

MAX 1,0 N m
MAX 8,85 lbf/in

1/4"

double door puerta doble

IMPORTANT: This is valid only if using a double pocket door without the Double Door Co-Ordination.

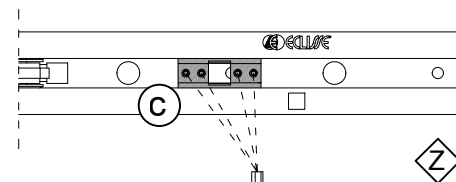
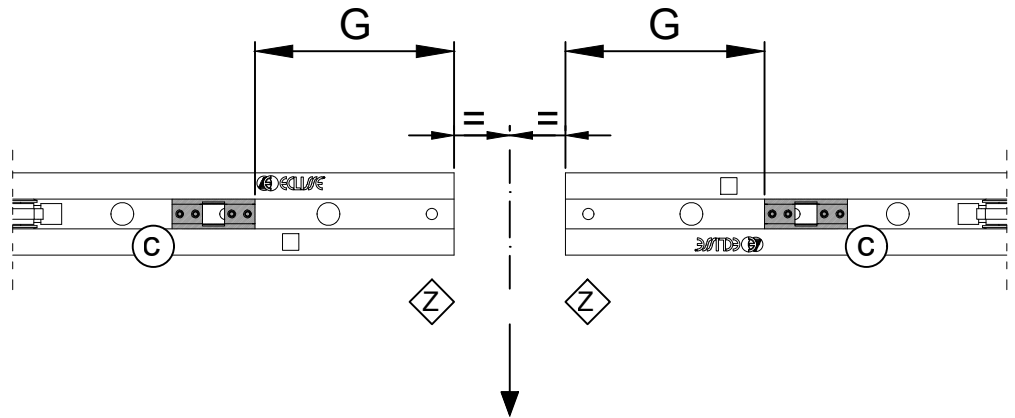
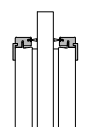
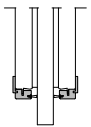

MAX 1,0 N m
MAX 8,85 lbf/in

1/4"

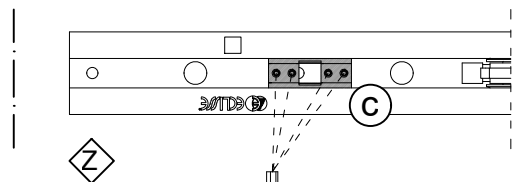

MAX 1,0 N m
MAX 8,85 lbf/in

1/4"

7

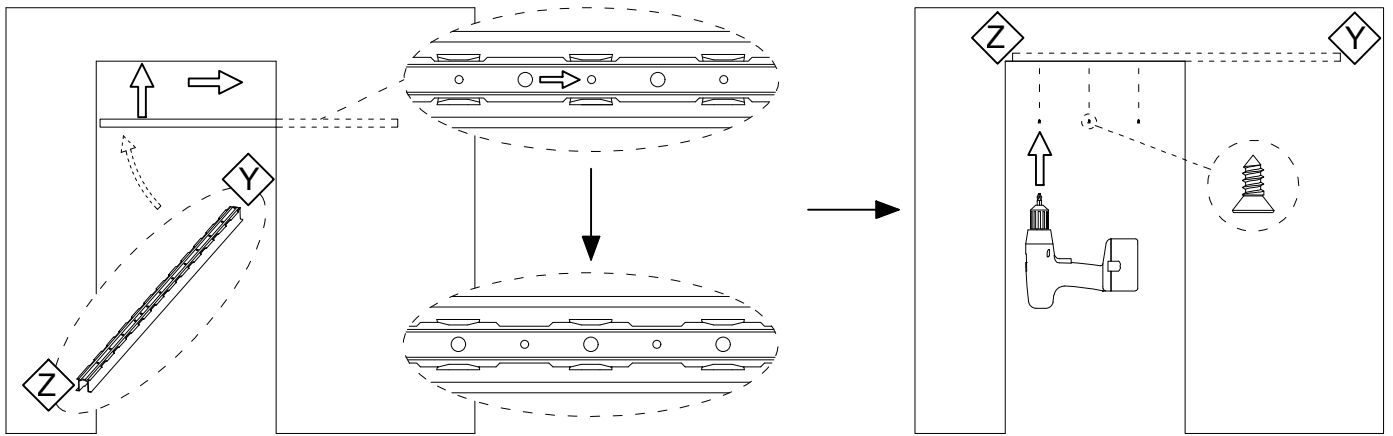

Insert the track back into the pocket system in reverse order of removal.

Vuelva a insertar el riel en el contramarco en orden inverso al de extracción.

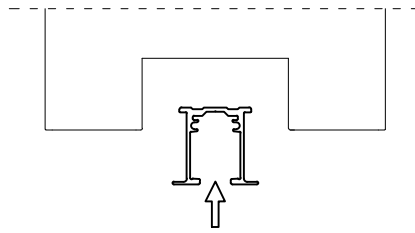

ALTERNATIVELY

Assembly the frame kit following the installation instructions inside the kit.

Montar el marco según las instrucciones de montaje dentro del kit.

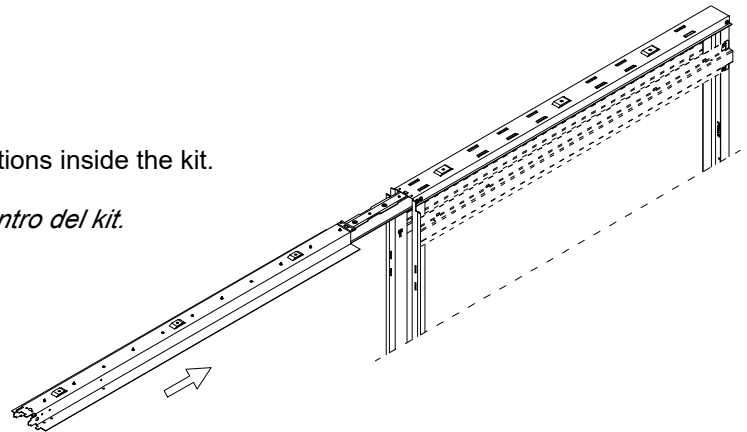

8

WARNING!

If the hanging bolt is adjusted too high, it will protrude through the top of the runner. If this happens, lower the door or trim down the bolt slightly.

ADVERTENCIA!

Si el perno colgante se ajusta demasiado alto, sobresaldrá por la parte superior del carro de deslizamiento. Si esto sucede, baje la puerta o recorte ligeramente el cerrojo.

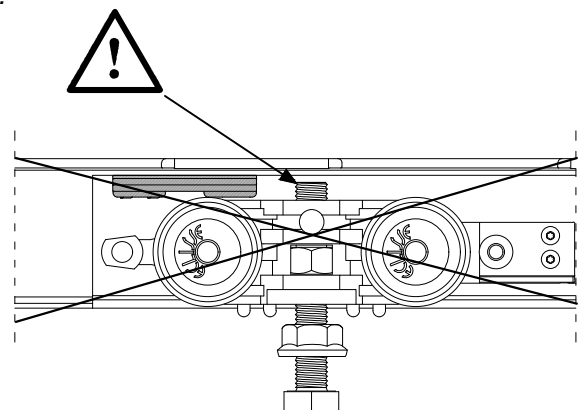
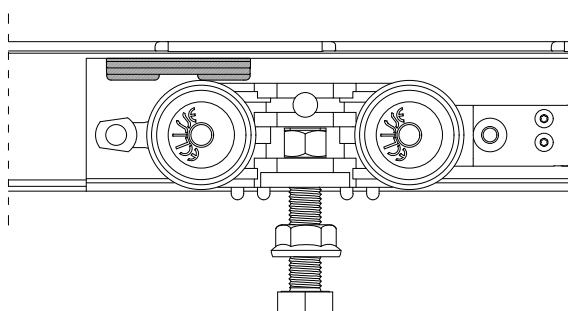
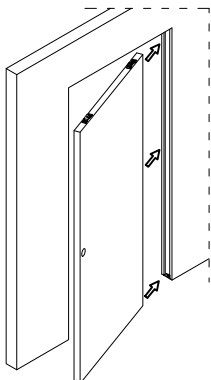

9

Fit the split jambs as shown. (* Jamb kit sold separately)

Coloque las molduras verticales como se muestra. (El kit de moldura se vende por separado)*

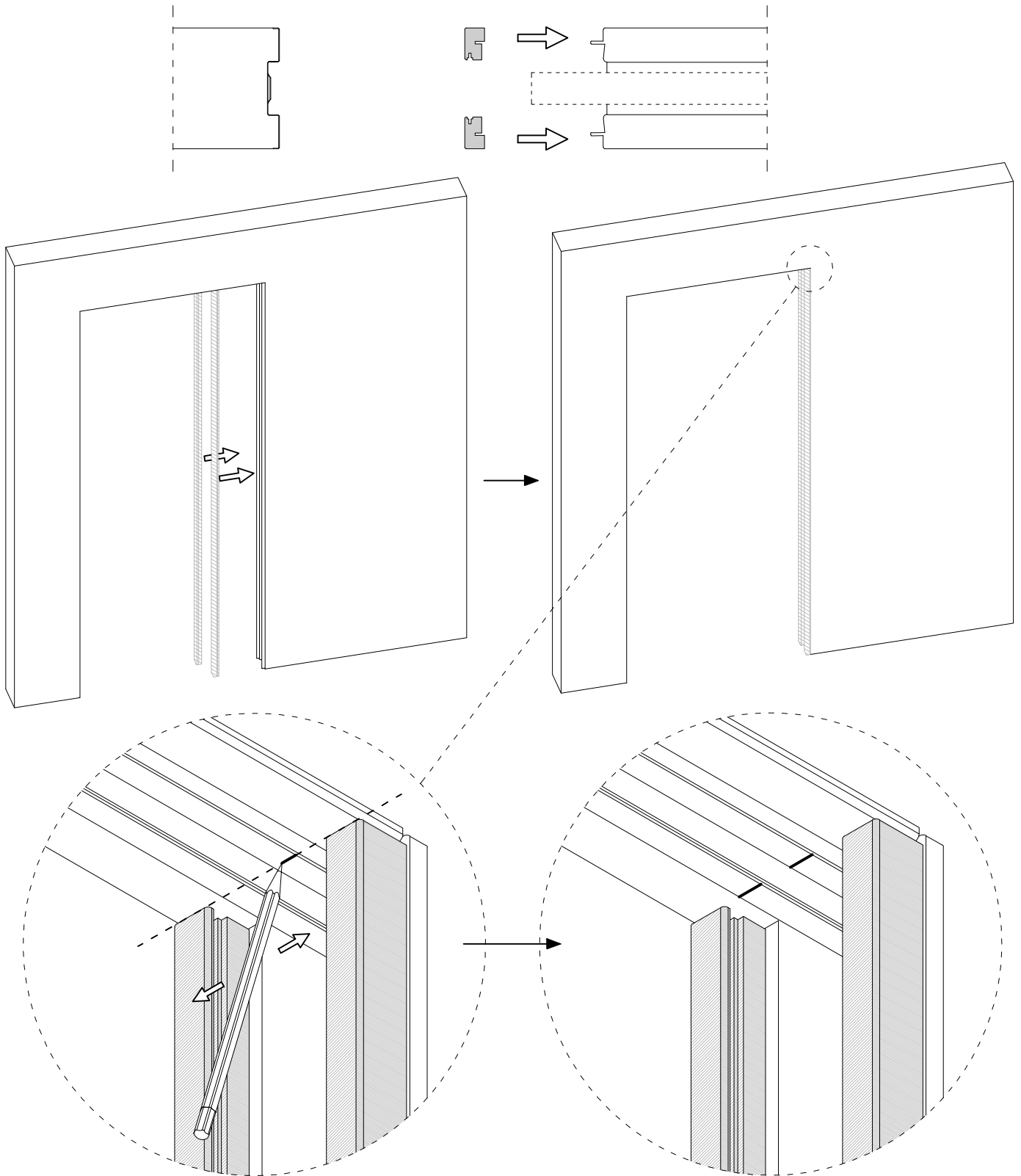

Draw a line across the track at the pocket entrance.

Dibuja una línea a través del riel en la entrada del marco.

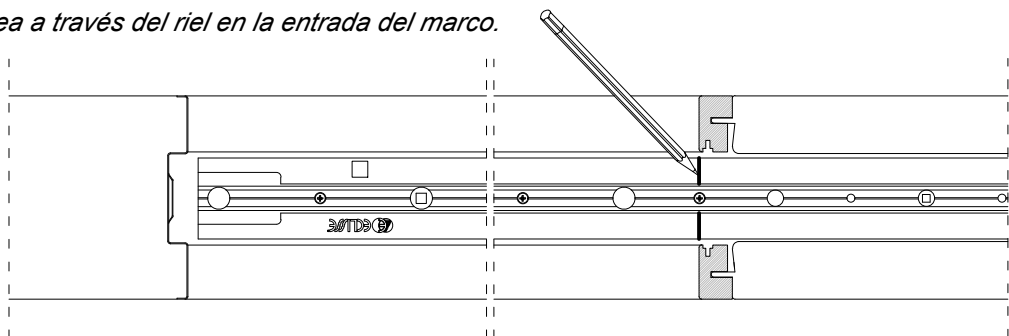

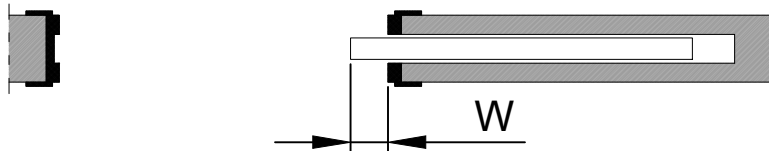

W = Dimension you wish the door to protrude when fully open. If you want the door to go completely inside the pocket, then it will be zero.

Dimensión que desea que sobresalga la puerta cuando esté completamente abierta. Si desea que la puerta entre completamente dentro del contramerco, entonces será cero.

K = The line drawn on the track at step 9.

La línea dibujada en el riel en el paso 9.

DOORS = 24" - 28"

For wooden doors:

K = 13-3/4"

For frameless glass doors:

K = 14-1/4"

DOORS = 30" or more

For wooden doors:

K = 14-1/2"

For frameless glass doors:

K = 15"

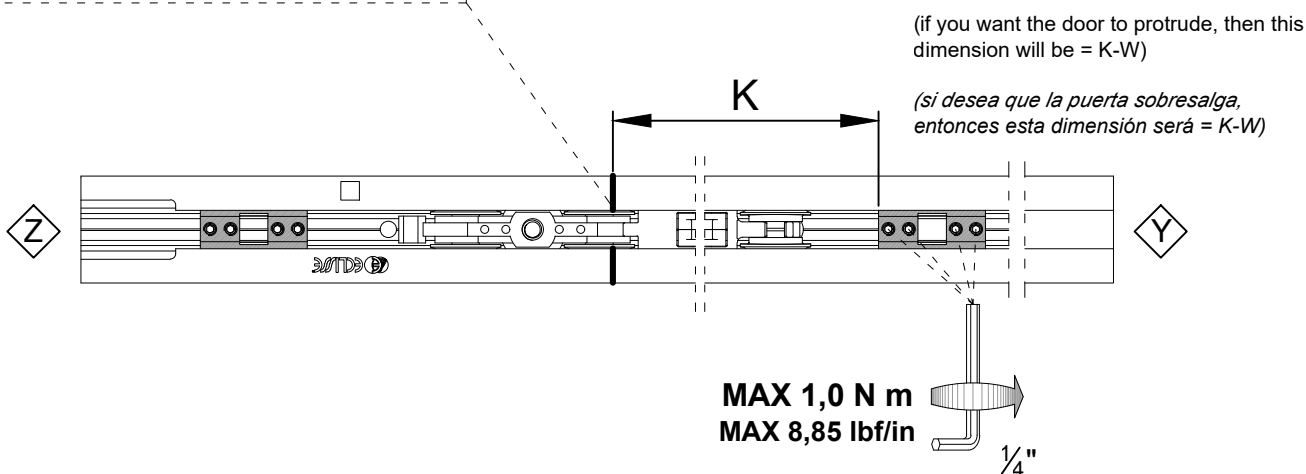
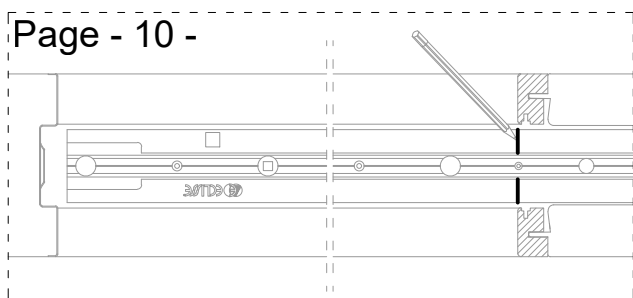

Set the activation bracket (c) into place at the required measure. Ensure all 4 grub screws are tight to prevent movement.

Coloque el soporte de activación (c) en su lugar.

Asegúrese de que los 4 tornillos prisioneros estén apretados para evitar el movimiento.

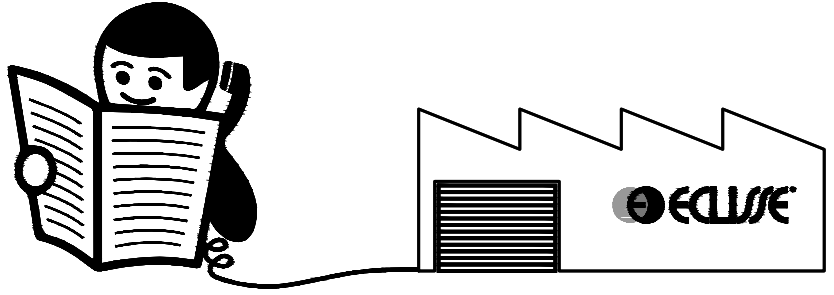
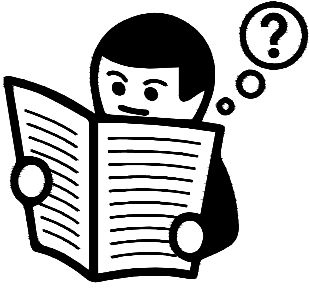

US ECLISSE NORTH AMERICA LLC - Tel.: +1 800 614 1474 - info@eclissena.com - www.eclisse.us

www.eclisse.us

